



City of Chicago



O2016-7815

Office of the City Clerk

Document Tracking Sheet

Meeting Date:	10/25/2016
Sponsor(s):	Villegas (36)
Type:	Ordinance
Title:	Grant(s) of privilege in public way for McGrath City Honda
Committee(s) Assignment:	Committee on Transportation and Public Way

ORDINANCE
MCGRATH CITY HONDA
Acct. No. 311637 - 2
Permit No. 1123166

Be It Ordained by the City Council of the City of Chicago:

SECTION 1. Permission and authority are hereby given and granted to MCGRATH CITY HONDA, upon the terms and subject to the conditions of this ordinance to maintain and use one (1) sign(s) projecting over the public right-of-way attached to its premises known as 6701 W. Grand Ave..

Said sign structure(s) measures as follows; along W Grand Ave:

One (1) at eight (8) feet in length, sixteen point nine two (16.92) feet in height and point five (.5) feet above grade level.

The location of said privilege shall be as shown on prints kept on file with the Department of Business Affairs and Consumer Protection and the Office of the City Clerk.

Said privilege shall be constructed in accordance with plans and specifications approved by the Department of Transportation (Division of Project Development) and Zoning Department - Signs.

This grant of privilege in the public way shall be subject to the provisions of Section 10-28-015 and all other required provisions of the Municipal Code of Chicago.

The grantee shall pay to the City of Chicago as compensation for the privilege #1123166 herein granted the sum of three hundred (\$300.00) per annum in advance.

A 25% penalty will be added for payments received after due date.

The permit holder agrees to hold the City of Chicago harmless for any damage, relocation or replacement costs associated with damage, relocation or removal of private property caused by the City performing work in the public way.

Authority herein given and granted for a period of five (5) years from and after Date of Passage.

Alderman _____

Gilbert Villegas 36th Ward

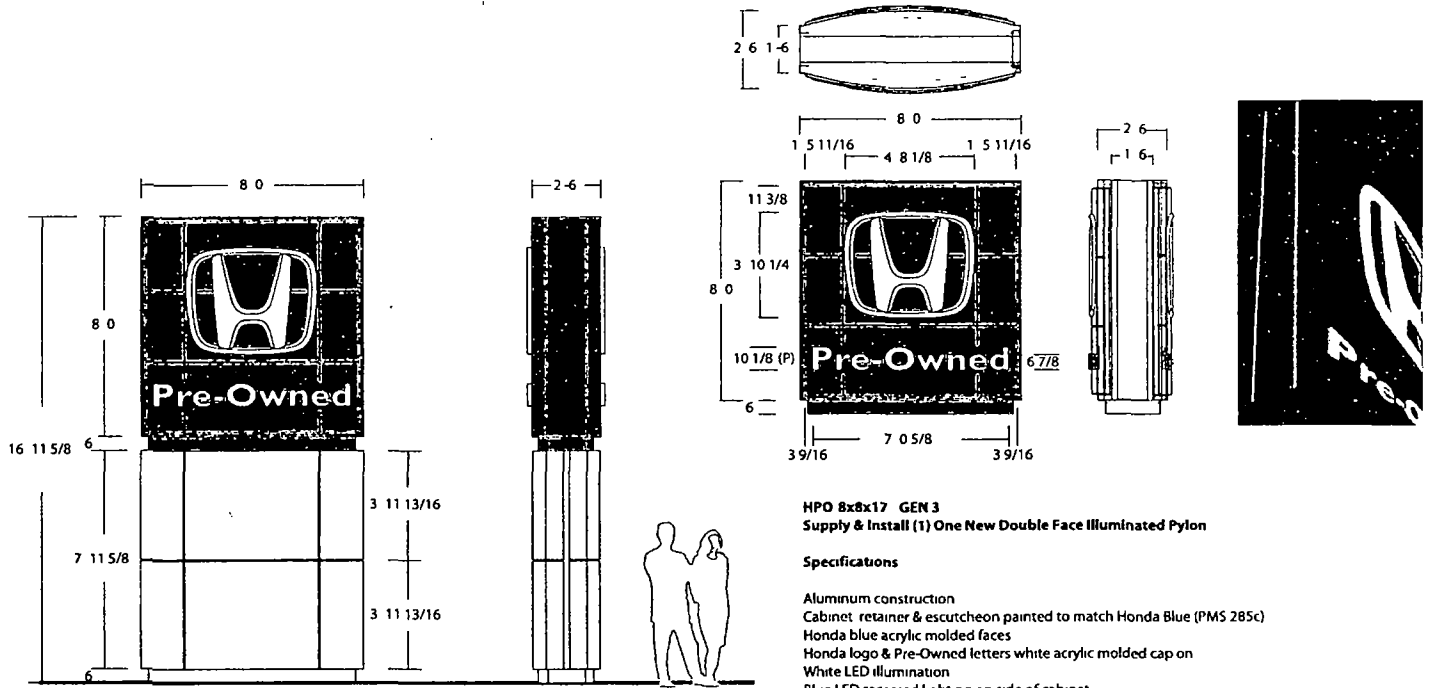

HPO 8x17 GEN 3
Supply & Install (1) One New Double Face Illuminated Pylon

Specifications

- Aluminum construction
 - Cabinet retainer & escutcheon painted to match Honda Blue (PMS 285c)
 - Honda blue acrylic molded faces
 - Honda logo & Pre-Owned letters white acrylic molded cap on
 - White LED illumination
 - Blue LED recessed lighting on side of cabinet
 - Electrical hook up by others
- Fiberglass cladding joint cover and bottom escutcheon Honda white



410 N Cedar Bluff Rd Suite 101 Knoxville TN 37923
 Tel (865) 693 1105 Fax (865) 694 1106 Toll Free (866) 218 1976

Customer Approval

Date

www.pattison.com

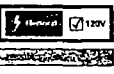
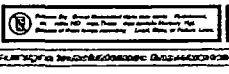
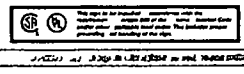

Client:	McGrath 208440
Site:	6720 West Grand Ave Chicago IL
Sales Rep:	Andrew Jackson
Order:	25AUG2012
Designer:	PL
Designer:	AJT 1410
Scale:	1/4" = 1' 0"



Department of Business Affairs and Consumer Protection
Small Business Center - Public Way Use Unit
City Hall - 121 N. LaSalle Street, Room 800 • Chicago, IL 60602
312-74-GOBIZ / 312-744-6249 • (312) 744-1944 (TTY)
<http://www.cityofchicago.org/bacp>

10/05/2016

Alderman **Gilbert Villegas**
Ward # 36
City of Chicago
City Hall, Room 200
121 North LaSalle Street
Chicago, Illinois 60602

Re: An ordinance to use and maintain a portion of the public right-of-way for **one (1) sign(s)** for **MCGRATH CITY HONDA**, adjacent to the premises known as **6701 W. Grand Ave.**

Dear Alderman **Gilbert Villegas**:

The applicant referenced above has requested the use of the public right-of-way for a **sign(s)**. An ordinance has been prepared by the Department of Business Affairs and Consumer Protection – Small Business Center - Public Way Use Unit for presentation to the City Council. Because this request was made for properties located in your ward, as approved by you as per the attached, I respectfully request that you introduce the attached ordinance at the next City Council meeting.

If you have any questions regarding this ordinance, please contact Anthony Bertuca at (312) 744-5506.

Department of Business Affairs and Consumer Protection