



Office of the Chicago City  
Clerk



O2011-7935

Office of the City Clerk

City Council Document Tracking Sheet

**Meeting Date:** 9/8/2011  
**Sponsor(s):** Tunney, Thomas (44)  
**Type:** Ordinance  
**Title:** Grant(s) of Privilege in Public Way for Yogurt Pier  
**Committee(s) Assignment:** Committee on Transportation and Public Way

ORDINANCE  
YOGURT PIER  
Acct. No. 360163 - 1  
Permit No. 1097417

*Be It Ordained by the City Council of the City of Chicago:*

SECTION 1. Permission and authority are hereby given and granted to YOGURT PIER, upon the terms and subject to the conditions of this ordinance to maintain and use one (1) sign(s) projecting over the public right-of-way attached to its premises known as 3510 N. Halsted St..

Said sign structure(s) measures as follows; along N. Halsted:  
One (1) at ten (10) feet in length, three (3) feet in height and ten (10) feet above grade level.

The location of said privilege shall be as shown on prints kept on file with the Department of Business Affairs and Consumer Protection and the Office of the City Clerk.

Said privilege shall be constructed in accordance with plans and specifications approved by the Department of Transportation (Division of Project Development) and Zoning Department - Signs.

This grant of privilege in the public way shall be subject to the provisions of Section 10-28-015 and all other required provisions of the Municipal Code of Chicago.

The grantee shall pay to the City of Chicago as compensation for the privilege #1097417 herein granted the sum of three hundred (\$300.00) per annum in advance.

A 25% penalty will be added for payments received after due date.

The permit holder agrees to hold the City of Chicago harmless for any damage, relocation or replacement costs associated with damage, relocation or removal of private property caused by the City performing work in the public way.

Authority herein given and granted for a period of five (5) years from and after Date of Passage.

Alderman



Thomas Tunney 44<sup>th</sup> Ward

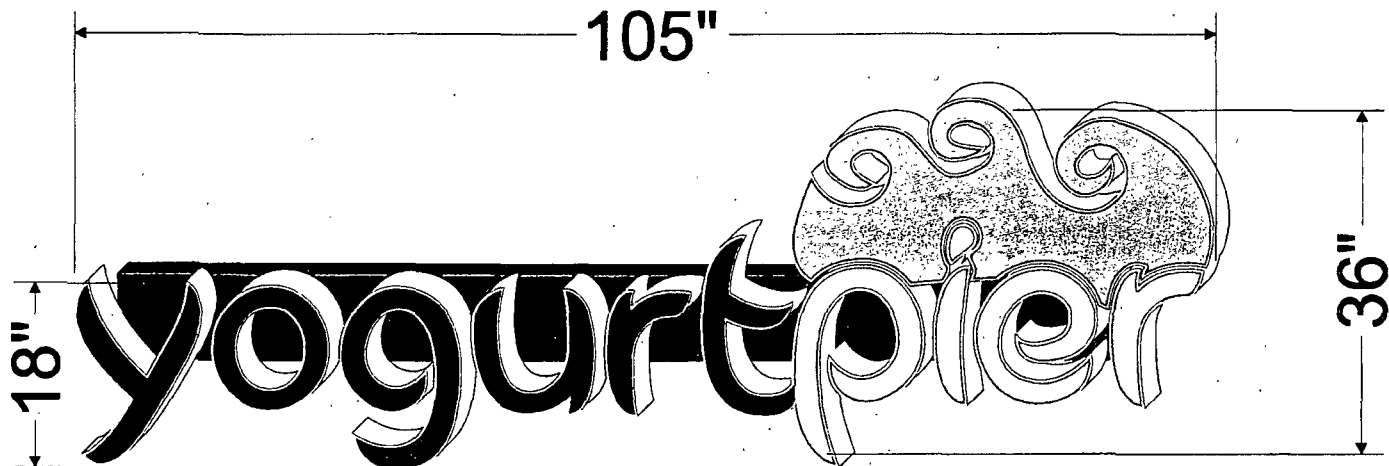

## General Specifications

### LED Raceway Mounting & SIDE VIEW

1. Building facade / sign band
2. LED power supply
3. Emergency turn off switch
4. 3/16" clear lexant for backlit
5. LED light
6. 0.040 aluminum return
7. Power supply
8. 1/2" x 4" Lag screw w/ anchors
9. Alluminum raceway
10. 1/4"x2.5x10" Mounting bracket
11. #8x Metal screws

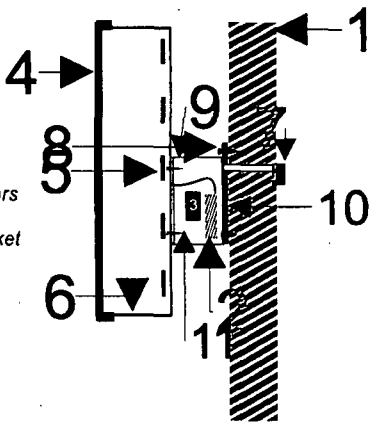

Sign Type		Raceway channel letters	
Illumination Type	Color	LED	White
Face material	Gauge	Plexiglass	3/16"
	Color		White
Graphic	Color	FDC Perf Mulberry, Gregory Vivid Green, Blue B032	
Retainer type	Size/Color	Trim-cap	1"/White
Return depth	Gauge/Color	5" .040	Aluminum /White
Back material	Gauge	Aluminum	.060
Raceway material	Gauge	Aluminum	.060
	Size/Color	6"x8"x176"	Matching Facade
Tube support	Type/Ht.		N/A
Transformer	Type/mA	LED transmitter	110V
Retainer screw		#4 x 0.5" lg Hex hd	
Neon electrical	Wire size	Remote wiring 600V 16AWG	
	Wire type	UL LED cable	
Boot insulated / Sleeve		None	
Electrical connectors		1/2" Greenfield	

Sign will be fastened directly to facade no exposed wiring

**EXPRESS SIGNS**  
 & Graphics Inc  
 Wholesale & Retail Interior / Exterior Signage  
 www.neonexpress.net  
 1-888-2NEONEX  
 5026 N. Broadway, Chicago, IL 60640

CUSTOMER: Yogurt Pier  
 LOCATION: 3510 N Hasted  
 Chicago, IL  
 Design By: TH  
 Date: 03/08/2011

Customer approval signature \_\_\_\_\_ Date 1 / 2011  
© by Express Signs  
 Proprietary and Confidential  
This design is the original and unpublished work of Express Sign & Graphics, Inc. and may not be reproduced copied or exhibited in any fashion without the expressed writing from an authorized personnel of the company. The rights to this design may be purchased

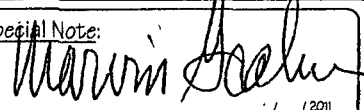
Special Note:  
  
 Alderman approval signature \_\_\_\_\_ Date 1 / 2011



**09/08/2011**

Alderman **Thomas Tunney**  
Ward # 44  
City of Chicago  
City Hall, Room 203  
121 North LaSalle Street  
Chicago, Illinois 60602

Re: An ordinance to use and maintain a portion of the public right-of-way for **one (1) sign(s)** for **YOGURT PIER**, adjacent to the premises known as **3510 N. Halsted St.**

Dear Alderman **Thomas Tunney**:

The applicant referenced above has requested the use of the public right-of-way for a **sign(s)**. An ordinance has been prepared by the Department of Business Affairs and Consumer Protection – Business Assistance Center - Public Way Use Unit for presentation to the City Council. Because this request was made for properties located in your ward, as approved by you as per the attached, I respectfully request that you introduce the attached ordinance at the next City Council meeting.

If you have any questions regarding this ordinance, please contact John Mariane, Manager, Business Assistance Center - Public Way Use Unit, at (312) 744-2063.

**Department of Business Affairs and Consumer Protection**