



City of Chicago



O2015-632

Office of the City Clerk

Document Tracking Sheet

Meeting Date:	1/21/2015
Sponsor(s):	Waguespack (32)
Type:	Ordinance
Title:	Grant(s) of privilege in public way for RoscoeBooks
Committee(s) Assignment:	Committee on Transportation and Public Way

ORDINANCE
RoscoeBooks
Acct. No. 393035 - 1
Permit No. 1115765

Be It Ordained by the City Council of the City of Chicago:

SECTION 1. Permission and authority are hereby given and granted to RoscoeBooks, upon the terms and subject to the conditions of this ordinance to maintain and use one (1) sign(s) projecting over the public right-of-way attached to its premises known as 2142 W. Roscoe St..

Said sign structure(s) measures as follows; along W. Roscoe Street:

One (1) at three point four two (3.42) feet in length, two point four two (2.42) feet in height and nine (9) feet above grade level.

The location of said privilege shall be as shown on prints kept on file with the Department of Business Affairs and Consumer Protection and the Office of the City Clerk.

Said privilege shall be constructed in accordance with plans and specifications approved by the Department of Transportation (Division of Project Development) and Zoning Department - Signs.

This grant of privilege in the public way shall be subject to the provisions of Section 10-28-015 and all other required provisions of the Municipal Code of Chicago.

The grantee shall pay to the City of Chicago as compensation for the privilege #1115765 herein granted the sum of one hundred (\$100.00) per annum in advance.

A 25% penalty will be added for payments received after due date.

The permit holder agrees to hold the City of Chicago harmless for any damage, relocation or replacement costs associated with damage, relocation or removal of private property caused by the City performing work in the public way.

Authority herein given and granted for a period of five (5) years from and after Date of Passage.

Alderman *Scott Waguespack*
Scott Waguespack 32nd Ward

By signing the Customer Acceptance on this print, I understand that I am accepting all aspects of this drawing. This includes artwork, specifications, dimensions, quantities, and all other representations herein. I also understand that color reproductions on this print are approximate, and may not match manufacturer's printed exactly.

CUSTOMER ACCEPTANCE SIGNATURE _____ DATE _____ IF REQUIRED: LANDLORD ACCEPTANCE SIGNATURE _____ DATE _____ L.S.G. SALES INITIALS _____ DATE _____



7434 Industrial Avenue
Chesterton, IN 46304
Phone 219 762-9577
Fax 219 762-8258
www.landmarksign.com

PRINT # **ML-21931-18**
MIKE LANOVICH
L.S.G. SALES REPRESENTATIVE

10.02.18
DATE

ROSCOE BOOKS
CLIENT NAME
2142 ROSCOE
CHICAGO, IL

JOB LOCATION
SCALE 1" = 1'-0"

REVISIONS
1 CHANGE TO ROUTED ONLY, NO PUSH THRU 10 10 14 JL

Designed
110 Volts
Electrical Connection will be Visible unless it is in line of Perspective.
Mounting Trip will be changed as Time & Material

THIS DRAWING IS THE PROPERTY OF LANDMARK SIGN GROUP, INC. REPRODUCTIONS OR COPIES ARE STRICTLY PROHIBITED WITHOUT THE EXPRESS PERMISSION OF LANDMARK SIGN GROUP, INC. ALL DIMENSIONS AND NOTES SHALL BE CONSIDERED TO TAKE PRECEDENCE OVER ANY OTHER PART OF THIS DRAWING.

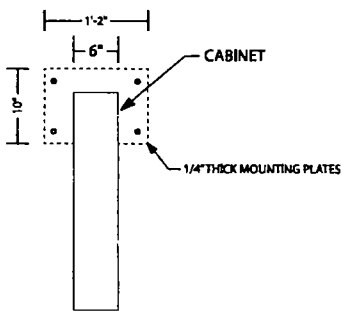

End View 1" = 1'-0"

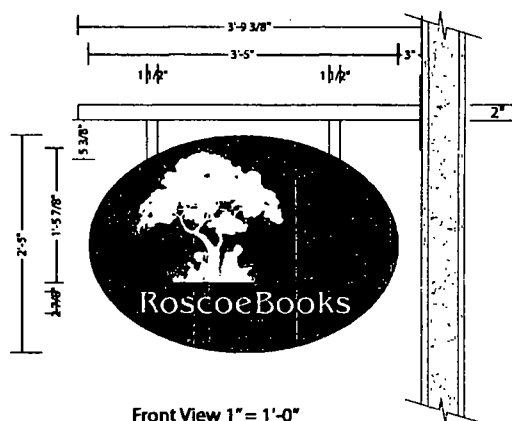

Front View 1" = 1'-0"

- ▶ ONE DOUBLE SIDED SIGN/ INTERNALLY ILLUMINATED WITH LEDS/ ROUTED ALUMINUM BACKED WITH PLEX AND TRANS VINYL / FLAG MOUNTED FROM BUILDING FASCIA
- SIGNCASE & BKGD = MAP TO MATCH 3630-76 HOLLY GREEN
LOGO = MILK WHITE PLEX with APPLIED 3630-156 VIVID GREEN & 3630-76 HOLLY GREEN OUTLINE
COPY = MILK WHITE PLEX
MOUNTING SUPPORTS AND BRACKETS = MAP WHITE

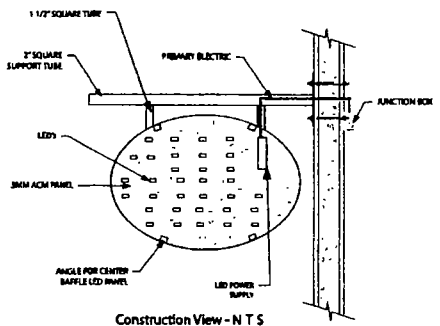

Construction View - N.T.S.





01/21/2015

Alderman **Scott Waguespack**
Ward # **32**
City of Chicago
City Hall, Room **300**
121 North LaSalle Street
Chicago, Illinois 60602

Re: An ordinance to use and maintain a portion of the public right-of-way for **one (1) sign(s)** for **RoscoeBooks**, adjacent to the premises known as **2142 W. Roscoe St.**

Dear Alderman **Scott Waguespack**:

The applicant referenced above has requested the use of the public right-of-way for a **sign(s)**. An ordinance has been prepared by the Department of Business Affairs and Consumer Protection – Small Business Center - Public Way Use Unit for presentation to the City Council. Because this request was made for properties located in your ward, as approved by you as per the attached, I respectfully request that you introduce the attached ordinance at the next City Council meeting.

If you have any questions regarding this ordinance, please contact Anthony Bertuca at (312) 744-5506.

Department of Business Affairs and Consumer Protection