



City of Chicago



O2013-7328

Office of the City Clerk

Document Tracking Sheet

Meeting Date:	9/11/2013
Sponsor(s):	Smith, Michele (43)
Type:	Ordinance
Title:	Grant(s) of privilege in public way for Perennial
Committee(s) Assignment:	Committee on Transportation and Public Way

ORDINANCE
PERENNIAL
Acct. No. 319410 - 1
Permit No. 1108051

Be It Ordained by the City Council of the City of Chicago:

SECTION 1. Permission and authority are hereby given and granted to PERENNIAL, upon the terms and subject to the conditions of this ordinance to maintain and use one (1) sign(s) projecting over the public right-of-way attached to its premises known as 1800 N. Lincoln Ave..

Said sign structure(s) measures as follows; along N. LINCOLN:
One (1) at four point five three (4.53) feet in length, nine point three three (9.33) feet in height and twelve point four two (12.42) feet above grade level.

The location of said privilege shall be as shown on prints kept on file with the Department of Business Affairs and Consumer Protection and the Office of the City Clerk.

Said privilege shall be constructed in accordance with plans and specifications approved by the Department of Transportation (Division of Project Development) and Zoning Department - Signs.

This grant of privilege in the public way shall be subject to the provisions of Section 10-28-015 and all other required provisions of the Municipal Code of Chicago.

The grantee shall pay to the City of Chicago as compensation for the privilege #1108051 herein granted the sum of three hundred (\$300.00) per annum in advance.

A 25% penalty will be added for payments received after due date.

The permit holder agrees to hold the City of Chicago harmless for any damage, relocation or replacement costs associated with damage, relocation or removal of private property caused by the City performing work in the public way.

Authority herein given and granted for a period of five (5) years from and after 07/30/2013.

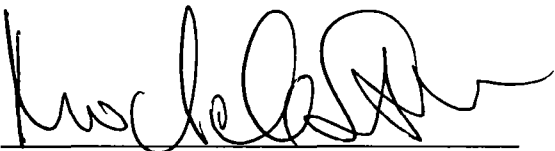
Alderman 

Michele Smith 43rd Ward

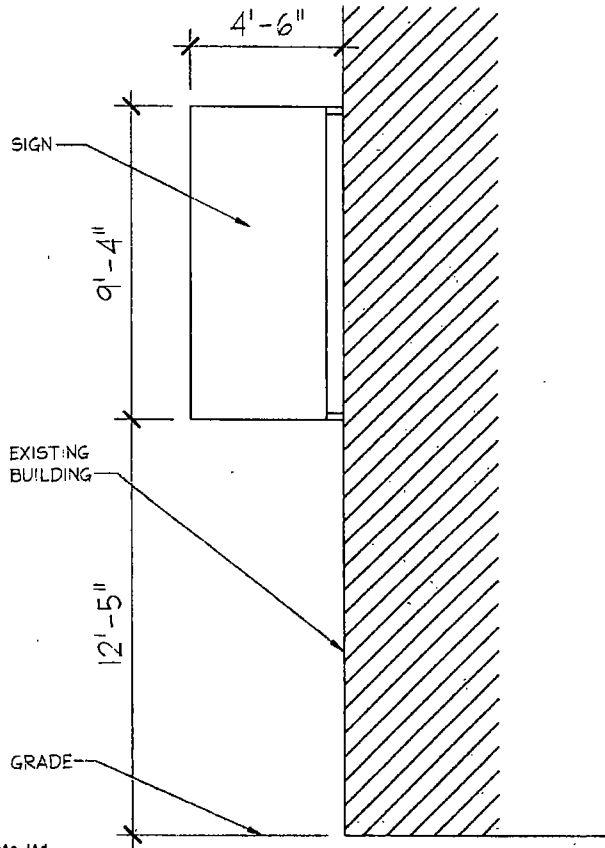

JSa
Jonathan SPLITT architects ltd.
4001 north ravenwood avenue
suite 801
chicago illinois 60613
773 863 1017 fax 773 883 3081

SIGN ELEVATION DRAWING

1/4"=1'-0"

1

proj. Perennial Virant
1500 N. Lincoln Avenue
CHICAGO, IL
date. 07.22.15
description

