



City of Chicago



O2021-3210

Office of the City Clerk

Document Tracking Sheet

| | |
|---------------------------------|--|
| Meeting Date: | 7/21/2021 |
| Sponsor(s): | La Spata (1) |
| Type: | Ordinance |
| Title: | Grant(s) of privilege in public way for Innovative Viewing |
| Committee(s) Assignment: | Committee on Transportation and Public Way |

ORDINANCE
INNOVATIVE VIEWING

Acct. No.: 470689 - 1

Permit No: BACP1548034

Be It Ordained by the City Council of the City of Chicago:

SECTION 1. Permission and authority are hereby given and granted to INNOVATIVE VIEWING upon the terms and subject to the conditions of this ordinance to maintain and use one (1) Sign(s) projecting over the public right-of-way attached to its premises known as 1644 W CHICAGO AVE.

Said Sign structure(s) measures as follows along 1644 W CHICAGO AVE:

One (1) at five (5) feet in length, four (4) feet in height and eleven (11) feet above grade level.

The location of said privilege shall be as shown on prints kept on file with the Department of Business Affairs and Consumer Protection and the Office of the City Clerk.

Said privilege shall be constructed in accordance with plans and specifications approved by the Zoning Department - Signs.

This grant of privilege in the public way shall be subject to the provisions of Section 10-28-015 and all other required provisions of the Municipal Code of Chicago.

The grantee shall pay to the City of Chicago as compensation for the privilege #BACP1548034 herein granted the sum of one hundred (\$100.00) per annum in advance.

A 25% penalty will be added for payments received after due date.

The permit holder agrees to hold the City of Chicago harmless for any damage, relocation or replacement costs associated with damage, relocation or removal of private property caused by the City performing work in the public way.

Authority herein given and granted for a period of five (5) years from and after Date of Passage.

Alderman:



Daniel LaSpata 1st Ward

WALL SIGN internally illuminated

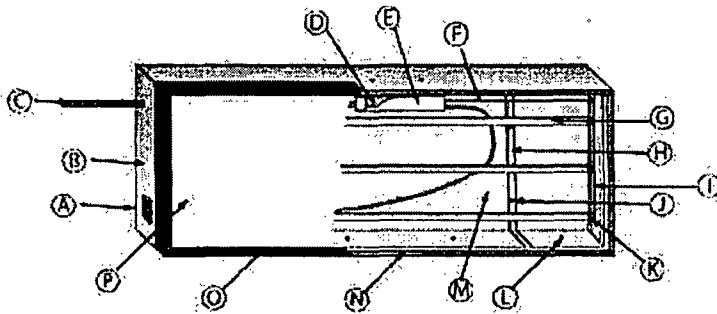
CROSS SECTION DETAIL

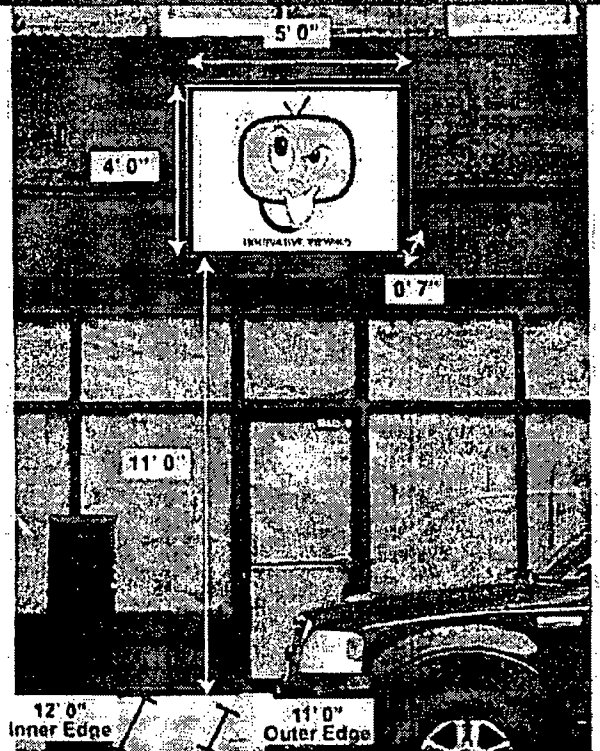

| | |
|---|------------------------------------|
| A | Isled thermostat switch |
| B | Aluminum seal |
| C | Primary Electrical source |
| D | H.D. Ballast |
| E | Ballast box |
| F | 1/2" glasshead |
| G | Fluorescent Lamp |
| H | 1 1/2" x 1 1/2" x 1/8" U Seal And |
| I | Wire way box |
| J | Installation Holes |
| K | Screen |
| L | Wedge Holes |
| M | 1/80 Sheet Metal Bar |
| N | 1 1/2" x 1 1/2" x 1/8" Steel Angle |
| O | 2 x 2 Aluminum Retainers |
| P | 3/16" White Lexon |



| | | |
|--|--|---|
| <p>General Contractor: FROMAGE PROMOTIONS INC. 1547 W. Chicago, Ave. Chicago, IL 60642 Tel. 773 292 1111 permits@allproimage.com</p> | <p>Location NORTH ELEVATION Address 1644 W CHICAGO AVE CHICAGO, IL. 60622</p> <p>Date: 06-07-2021</p> | <p>Description</p> <ul style="list-style-type: none"> - SINGLE SIDED DISPLAY - WALL MOUNTED. - FULL COLOR VINYL LETTERING - 3/16 WHITE LEXON. - INTERNALLY ILLUMINATE 8 FT. FLOURESCENT LAMPS - READS: INNOVATIVE VIEWING <p>Client INNOVATIVE VIEWING</p> |
|--|--|---|



Department of Business Affairs and Consumer Protection
Small Business Center - Public Way Use Unit
City Hall - 121 N. LaSalle Street, Room 800, Chicago, IL 60602
312-74-GOBIZ / 312-744-6249 • (312) 744-1944 (TTY)
<http://www.cityofchicago.org/bacp>

07/21/2021

Alderman Daniel LaSpata
Ward # 01
City of Chicago
City Hall, Room 800
121 N. LaSalle Street
Chicago, IL 60602

Re: An ordinance to use and maintain a portion of the public right-of-way for **1 Sign(s)** for **INNOVATIVE VIEWING**, adjacent to the premises known as **1644 W CHICAGO AVE.**

Dear Alderman **Daniel LaSpata**:

The applicant referenced above has requested the use of the public right-of-way for **Sign(s)**. An ordinance has been prepared by the Department of Business Affairs and Consumer Protection - Small Business Center - Public Way Use Unit for presentation to the City Council. Because this request was made for properties located in your ward, as approved by you as per the attached, I respectfully request that you introduce the attached ordinance at the next City Council meeting.

If you have any questions regarding this ordinance, please contact Anthony Bertuca at (312) 744-5506.

Department of Business Affairs and Consumer Protection