



City of Chicago



O2017-2782

Office of the City Clerk

Document Tracking Sheet

Meeting Date:	3/29/2017
Sponsor(s):	Reilly (42)
Type:	Ordinance
Title:	Canopy(s) for Thor 133 State LLC
Committee(s) Assignment:	Committee on Transportation and Public Way

ORDINANCE
THOR 133 STATE LLC
Acct. No. 361856 - 1
Permit No. 1125725

Be It Ordained by the City Council of the City of Chicago:

SECTION 1. Permission and authority are hereby given and granted to THOR 133 STATE LLC, upon the terms and subject to the conditions of this ordinance to maintain and use, as now constructed, three (3) Canopy(s) projecting over the public right-of-way adjacent to its premises known as 133 S. State St..

Said Canopy(s) at S. STATE measure(s):

One (1) at thirty-eight (38) feet in length, and four (4) feet in width for a total of one hundred fifty-two (152) square feet.

Said Canopy(s) at S. STATE measure(s):

Two (2) at thirty-eight (38) feet in length, and point seven five (.75) feet in width for a total of fifty-seven (57) square feet.

The location of said privilege shall be as shown on prints kept on file with the Department of Business Affairs and Consumer Protection and the Office of the City Clerk.

Said privilege shall be constructed in accordance with plans and specifications approved by the Zoning Department - Signs.

This grant of privilege in the public way shall be subject to the provisions of Section 10-28-015 and all other required provisions of the Municipal Code of Chicago.

The grantee shall pay to the City of Chicago as compensation for the privilege #1125725 herein granted the sum of one hundred seventy-five (\$175.00) per annum in advance.

A 25% penalty will be added for payments received after due date.

The permit holder agrees to hold the City of Chicago harmless for any damage, relocation or replacement costs associated with damage, relocation or removal of private property caused by the City performing work in the public way.

Authority herein given and granted for a period of five (5) years from and after 07/06/2016.

Alderman _____

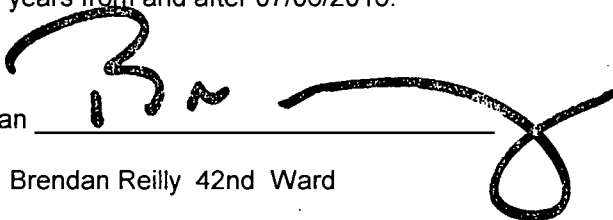
A handwritten signature in black ink, appearing to read 'Brendan Reilly', written over a horizontal line. The signature is stylized with a large 'B' and a long, sweeping tail.

Brendan Reilly 42nd Ward

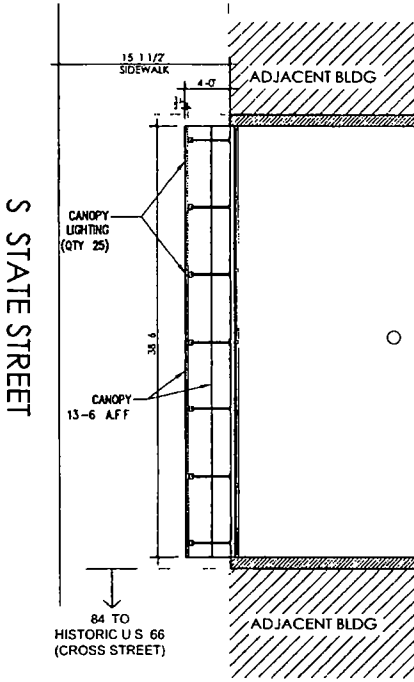

GROUND FLOOR PLAN
SCALE 1/8" = 1'-0"

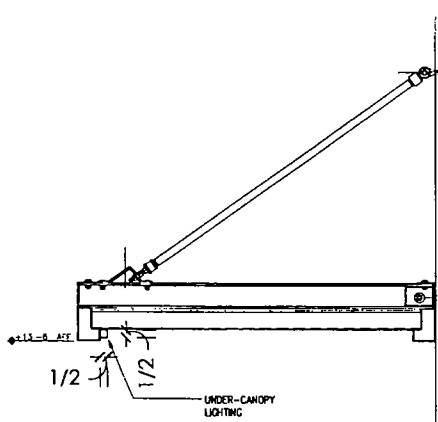

SECTION @ CANOPY
SCALE 1/8" = 1'-0"

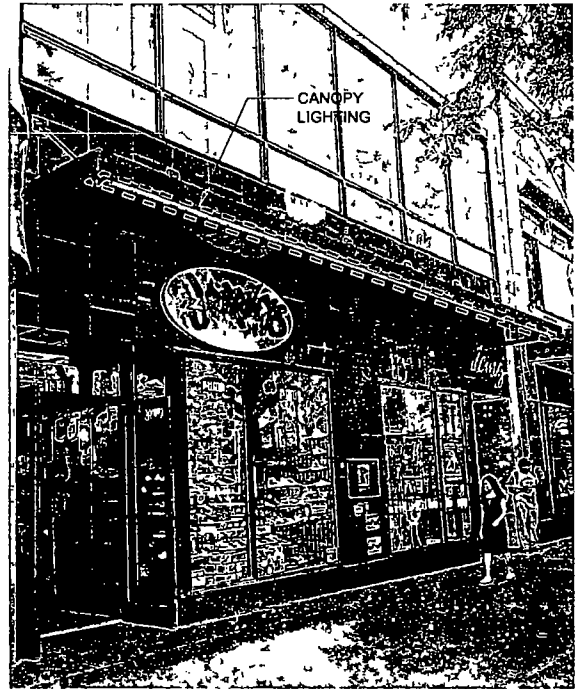

PHOTO OF FACADE - EXISTING CANOPY
SCALE NTS



25 WEST 39TH STREET
NEW YORK N Y 10018
TEL 212 529 5055

THIS EXHIBIT IS PROVIDED FOR ILLUSTRATIVE PURPOSES ONLY AND SHALL NOT BE DEEMED TO BE A WARRANTY REPRESENTATION OR AGREEMENT BY LANDLORD THAT THE PREMISES COMMON AREAS BUILDINGS AND/OR EXHIBIT WILL BE AS ILLUSTRATED ON THIS EXHIBIT OR THAT ANY TENANTS WHICH MAY BE REFERENCED ON THIS EXHIBIT WILL AT ANY TIME BE OCCUPANTS OF THE CENTER. LANDLORD RESERVES THE RIGHT TO MODIFY SIZE, CONFIGURATION AND OCCUPANTS OF THE PREMISES AT ANY TIME.

133 SOUTH STATE STREET
CHICAGO IL
2016-08-30
MP

AS-B