



City of Chicago



O2015-8373

Office of the City Clerk

Document Tracking Sheet

Meeting Date:	11/18/2015
Sponsor(s):	Reilly (42)
Type:	Ordinance
Title:	Awning(s) for Roanoke Hospitality LLC
Committee(s) Assignment:	Committee on Transportation and Public Way

ORDINANCE
ROANOKE HOSPITALITY, LLC
Acct. No. 398305 - 2
Permit No. 1120246

Be It Ordained by the City Council of the City of Chicago:

SECTION 1. Permission and authority are hereby given and granted to ROANOKE HOSPITALITY, LLC, upon the terms and subject to the conditions of this ordinance to construct, install, maintain and use one (1) Awning(s) projecting over the public right-of-way adjacent to its premises known as 135 W. Madison St..

Said Awning(s) at W. Madison Street measure(s):

One (1) at fifteen (15) feet in length, and two point one seven (2.17) feet in width for a total of thirty-two point five five (32.55) square feet.

The location of said privilege shall be as shown on prints kept on file with the Department of Business Affairs and Consumer Protection and the Office of the City Clerk.

Said privilege shall be constructed in accordance with plans and specifications approved by the Zoning Department - Signs.

This grant of privilege in the public way shall be subject to the provisions of Section 10-28-015 and all other required provisions of the Municipal Code of Chicago.

The grantee shall pay to the City of Chicago as compensation for the privilege #1120246 herein granted the sum of fifty (\$50.00) per annum in advance.

A 25% penalty will be added for payments received after due date.

The permit holder agrees to hold the City of Chicago harmless for any damage, relocation or replacement costs associated with damage, relocation or removal of private property caused by the City performing work in the public way.

Authority herein given and granted for a period of five (5) years from and after Date of Passage.

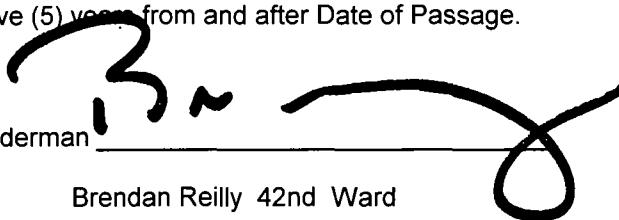
Alderman _____
Brendan Reilly 42nd Ward

1. The first part of the document discusses the importance of maintaining accurate records of all transactions and activities. It emphasizes that this is crucial for ensuring transparency and accountability in the organization's operations.

2. The second part of the document outlines the various methods and tools used to collect and analyze data. It highlights the need for consistent and reliable data collection processes to support informed decision-making.

3. The third part of the document focuses on the role of technology in enhancing data management and analysis. It discusses how modern software solutions can streamline data collection, storage, and reporting, thereby improving efficiency and accuracy.

4. The final part of the document provides a summary of the key findings and recommendations. It stresses the importance of ongoing monitoring and evaluation to ensure that the data collection and analysis processes remain effective and up-to-date.

roanoke

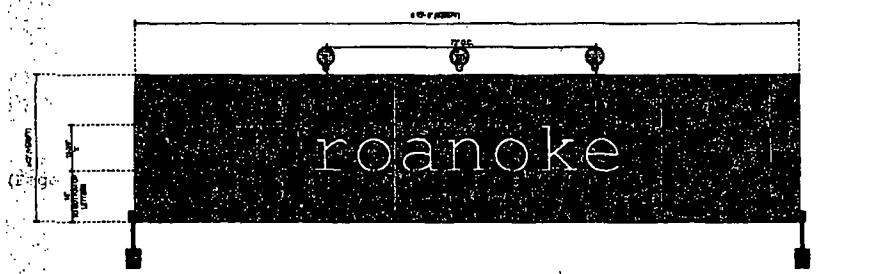

GRAPHICS ARE MASKED AND PAINTED IN LATEX PAINT, METALLIC GOLD (TO MATCH MP 3100 BRILLIANT GOLD OR EQUIV)

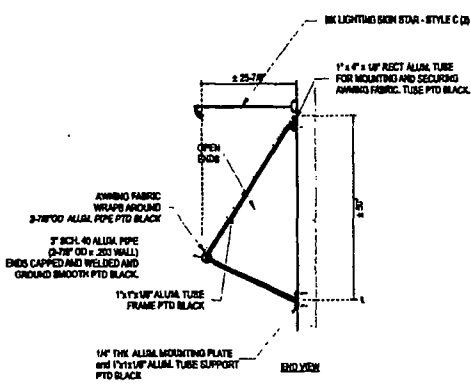

B MAIN ENTRY AWNING
SCALE 1/2" = 1'-0"

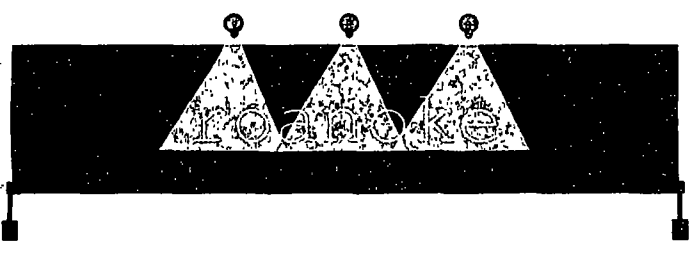

NIGHT VIEW

roanoke	
Company	
WEBER DRILL (owner)	
1211 N. P...	
Chicago, IL 60603	
Client	3 of 8
Address	31 & LAVALLE ST CHICAGO, IL 60603
Account	J DOVINS
Designer	J HODGKINSON
Date	03/02/15
Project # 110...	
Client	
Scale	
Contracting	
Art	
Engineering	
License	
Chandler Signs	
11111 S. ...	
Chicago, IL 60603	
Phone: 773-555-1234	
Fax: 773-555-5678	
E-mail: info@chandler-signs.com	
Web: www.chandler-signs.com	
© 2015 Chandler Signs, Inc. All rights reserved.	
FINAL ELECTRICAL CONNECTION BY CUSTOMER	