



Office of the Chicago City
Clerk



O2011-10136

Office of the City Clerk

City Council Document Tracking Sheet

Meeting Date:	12/14/2011
Sponsor(s):	Reilly, Brendan (42)
Type:	Ordinance
Title:	Grant(s) of Privilege in Public Way for Schatz Building, LLC
Committee(s) Assignment:	Committee on Transportation and Public Way

ORDINANCE
SCHATZ BUILDING, LLC
Acct. No. 362642 - 1
Permit No. 1097033

Be It Ordained by the City Council of the City of Chicago:

SECTION 1. Permission and authority are hereby given and granted to SCHATZ BUILDING, LLC, upon the terms and subject to the conditions of this ordinance to maintain and use one (1) sign(s) projecting over the public right-of-way attached to its premises known as 610 N. Fairbanks Ct..

Said sign structure(s) measures as follows; along E. Ontario St.:

One (1) at two point three three (2.33) feet in length, eight (8) feet in height and twelve (12) feet above grade level.

The location of said privilege shall be as shown on prints kept on file with the Department of Business Affairs and Consumer Protection and the Office of the City Clerk.

Said privilege shall be constructed in accordance with plans and specifications approved by the Department of Transportation (Division of Project Development) and Zoning Department - Signs.

This grant of privilege in the public way shall be subject to the provisions of Section 10-28-015 and all other required provisions of the Municipal Code of Chicago.

The grantee shall pay to the City of Chicago as compensation for the privilege #1097033 herein granted the sum of one hundred (\$100.00) per annum in advance.

A 25% penalty will be added for payments received after due date.

The permit holder agrees to hold the City of Chicago harmless for any damage, relocation or replacement costs associated with damage, relocation or removal of private property caused by the City performing work in the public way.

Authority herein given and granted for a period of five (5) years from and after Date of Passage.

Alderman _____

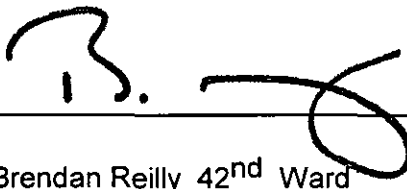
Brendan Reilly 42nd Ward

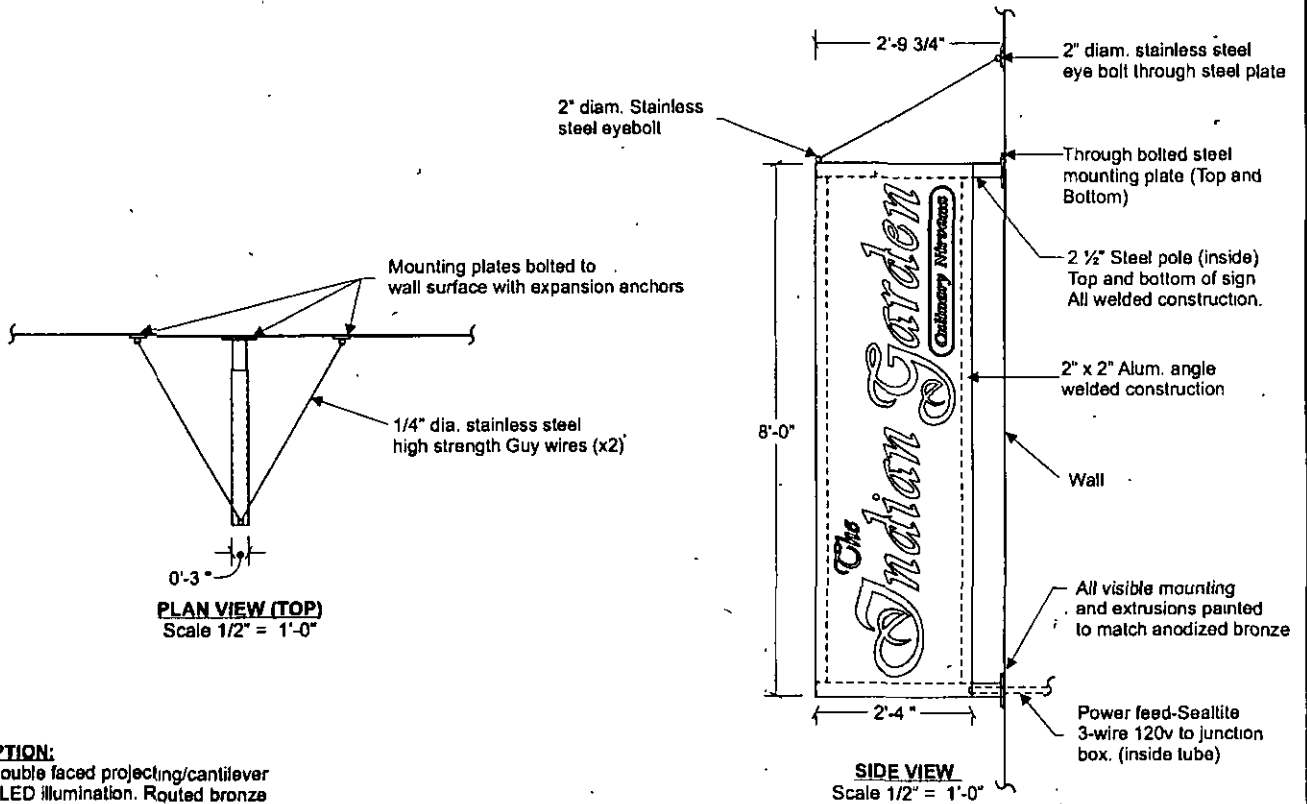

DESCRIPTION:

One (1) double faced projecting/cantilever sign with LED illumination. Routed bronze anodized aluminum faces with white translucent acrylic backer for lettering. (DSG to provide material samples)

TOTAL SIGN AREA
= 18.5 sq. Ft.

NOTE
120 v POWER SUPPLY UL LISTED

Approved:

Date:



2135 S Frontage Rd.
Des Plaines, IL 60018
847-390-0350 fax 847-390-9231
jillmore@designgroupsignage.com

4376-1
Schatz Dey
Indian Garden

Name:	Date:
PD	08 23 2011
PD	08 26 2011
PD	10 25 2011

Notes:
Initial Sign Drawings
Const and mounting detail
Call out revisions.



These plans are the exclusive property of DesignGroup Signage Corp. and are the result of the original work of its employees. They are submitted to your company for the sole purpose of your consideration of whether to purchase these plans or to purchase from DesignGroup Signage Corp. a sign manufactured according to these plans. Distribution or exhibition of these plans to construct a sign similar to the one herein is strictly forbidden. In the event that such exhibition occurs, DesignGroup Signage Corp. expects to be reimbursed \$500.00 in compensation for time and effort entailed in creating these plans.

Drawn By: PD

