



City of Chicago



O2015-8755

Office of the City Clerk

Document Tracking Sheet

Meeting Date:	12/9/2015
Sponsor(s):	Burnett (27)
Type:	Ordinance
Title:	Grant(s) of privilege in public way for Urban Source LLC
Committee(s) Assignment:	Committee on Transportation and Public Way

ORDINANCE
URBAN SOURCE, LLC
Acct. No. 289148 - 2
Permit No. 1120806

Be It Ordained by the City Council of the City of Chicago:

SECTION 1. Permission and authority are hereby given and granted to URBAN SOURCE, LLC, upon the terms and subject to the conditions of this ordinance to maintain and use, as now constructed, two (2) Light Fixture(s) projecting over the public right-of-way adjacent to its premises known as 1429 W. Chicago Ave..

Said Light Fixture(s) at W. CHICAGO AVE. measure(s):

Two (2) at point one six (.16) feet in length, point one six (.16) feet in width and fourteen (14) feet above grade level.

The location of said privilege shall be as shown on prints kept on file with the Department of Business Affairs and Consumer Protection and the Office of the City Clerk.

Said privilege shall be constructed in accordance with plans and specifications approved by the Department of Transportation (Division of Project Development).

This grant of privilege in the public way shall be subject to the provisions of Section 10-28-015 and all other required provisions of the Municipal Code of Chicago.

The grantee shall pay to the City of Chicago as compensation for the privilege #1120806 herein granted the sum of seventy-five (\$75.00) per annum in advance.

A 25% penalty will be added for payments received after due date.

The permit holder agrees to hold the City of Chicago harmless for any damage, relocation or replacement costs associated with damage, relocation or removal of private property caused by the City performing work in the public way.

Authority herein given and granted for a period of five (5) years from and after 12/08/2015.

Alderman



Walter Burnett Jr. 27th Ward

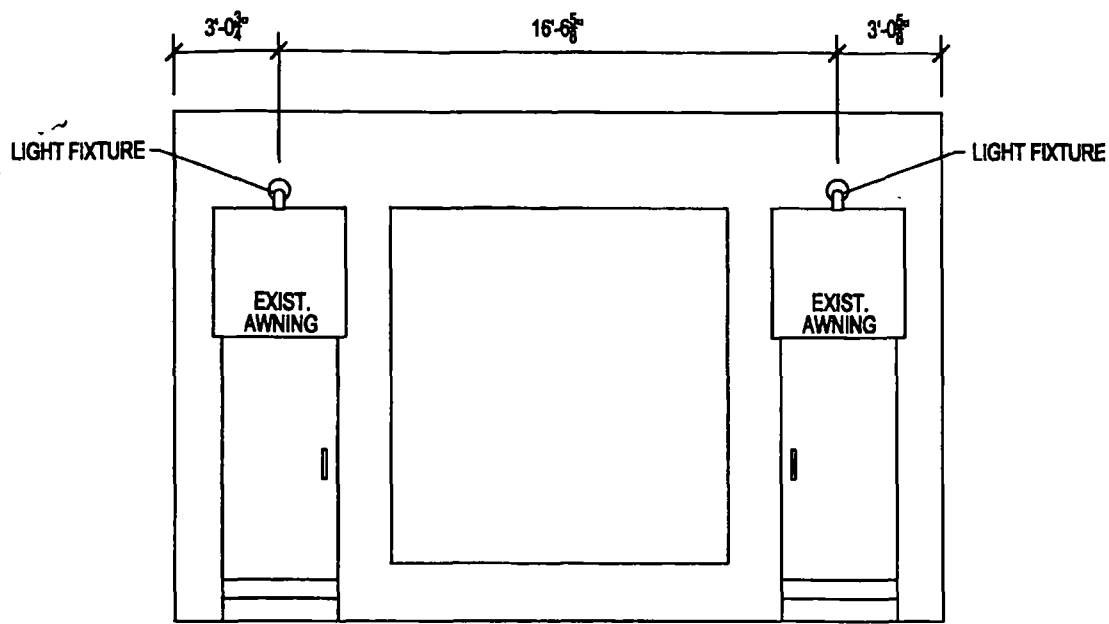

○ FRONT ELEVATION
SCALE: 3/16" = 1'-0"

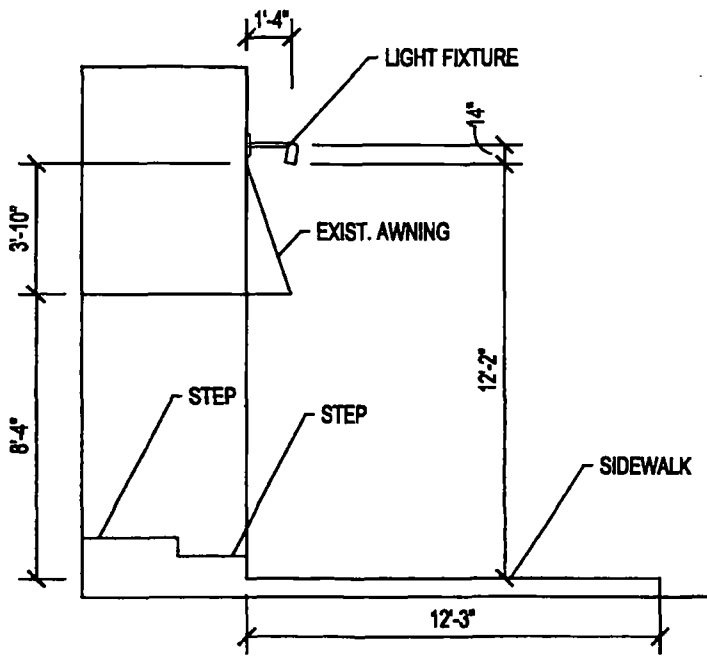

○ SECTION
SCALE: 3/16" = 1'-0"

Urban Source
1429 W Chicago Ave, Chicago, IL 60642
Distance to nearest cross street (Bishop) 85'-0"