



City of Chicago



O2016-6954

Office of the City Clerk

Document Tracking Sheet

Meeting Date:	9/14/2016
Sponsor(s):	Zalewski (23)
Type:	Ordinance
Title:	Grant(s) of privilege in public way for Verizon Wireless
Committee(s) Assignment:	Committee on Transportation and Public Way

ORDINANCE
Verizon Wireless
Acct. No. 207988 - 81
Permit No. 1122579

Be It Ordained by the City Council of the City of Chicago:

SECTION 1 Permission and authority are hereby given and granted to Verizon Wireless, upon the terms and subject to the conditions of this ordinance to construct, install, maintain and use Occupation of Space (Cell Antenna System) projecting over the public right-of-way adjacent to its premises known as 5219 S. Newcastle Ave..

Said Occupation of Space ((Cell Antenna System) at S. New Castle measure(s):
One (1) at two point two five (2.25) feet in length, and two (2) feet in width for a total of four point five (4.5) square feet. Cell antenna system shall be approximately thirty-two (32) feet above grade level.

The location of said privilege shall be as shown on prints kept on file with the Department of Business Affairs and Consumer Protection and the Office of the City Clerk.

Said privilege shall be constructed in accordance with plans and specifications approved by the Department of Planning and Development, Department of Transportation (Division of Project Development), and Department of Transportation (Office of Underground Coordination)

This grant of privilege in the public way shall be subject to the provisions of Section 10-28-015 and all other required provisions of the Municipal Code of Chicago.

The grantee shall pay to the City of Chicago as compensation for the privilege #1122579 herein granted the sum of four hundred (\$400.00) per annum in advance.

A 25% penalty will be added for payments received after due date.

The permit holder agrees to hold the City of Chicago harmless for any damage, relocation or replacement costs associated with damage, relocation or removal of private property caused by the City performing work in the public way.

Authority herein given and granted for a period of five (5) years from and after Date of Passage.

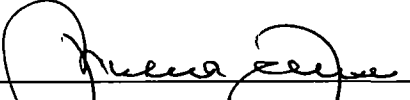
Alderman 
Michael R. Zalewski 23rd Ward

Prepared By SP
Checked By RVS

Job # T143528
Date 3/11/2016

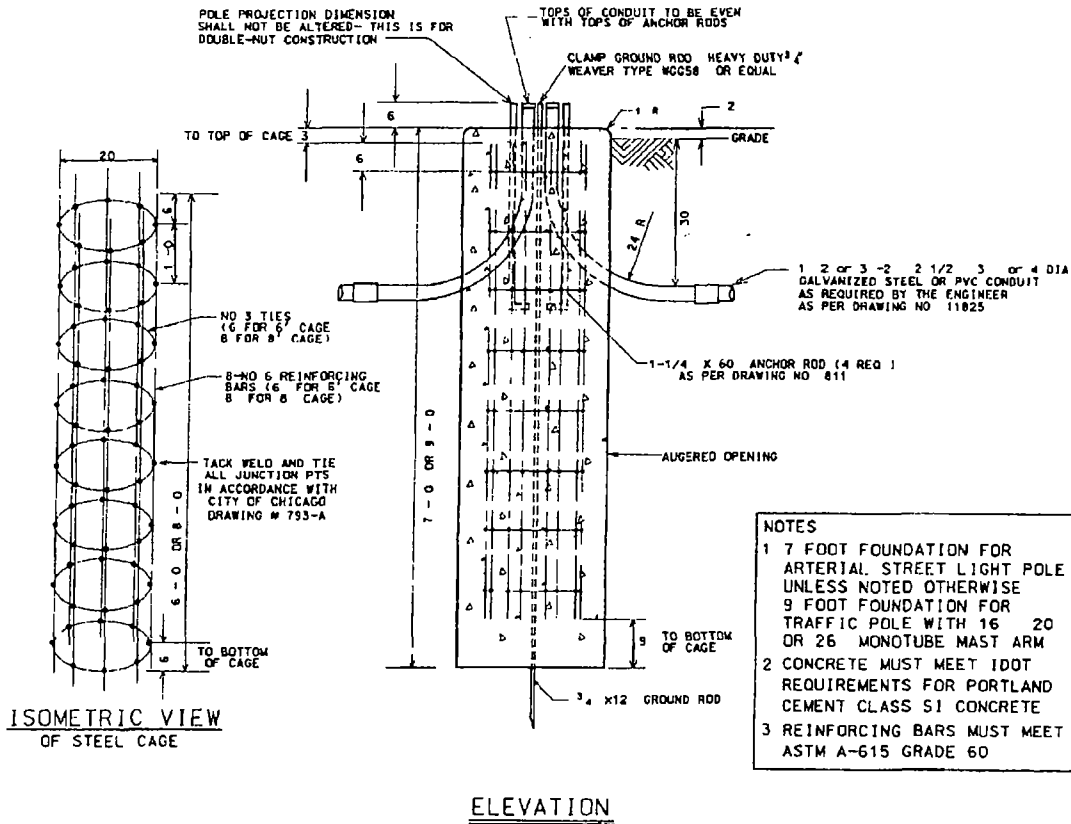
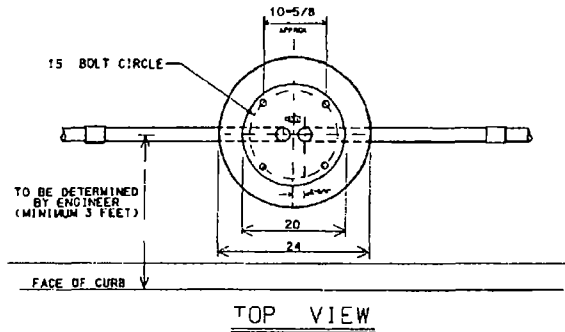

NOTES
1 7 FOOT FOUNDATION FOR ARTERIAL STREET LIGHT POLE UNLESS NOTED OTHERWISE
9 FOOT FOUNDATION FOR TRAFFIC POLE WITH 16 20 OR 26 MONOTUBE MAST ARM
2 CONCRETE MUST MEET IDOT REQUIREMENTS FOR PORTLAND CEMENT CLASS S1 CONCRETE
3 REINFORCING BARS MUST MEET ASTM A-615 GRADE 60

NOTE HOLE FOR FOUNDATION MUST BE AUGERED IN UNDISTURBED SOIL

CODE	COMMODITY	SIZE	QUANTITY
03 3267-2940	REDI-MIX CONCRETE	CU YD	0.82 OR 1.05
09-4001-	ELBOW LARGE RADIUS	2 2-1/2" X 3 4	VARIES
37-8180-0200	ANCHOR ROD	1-1/4" X 60"	4
05-5054-6810	RE-BAR CAGE	20" X 6 (or 8)	1
09-7796-9200	GROUND ROD	3/4" X 12'-0"	1
09-2636-3240	GROUND ROD CLAMP	3/4"	1
09 2092-	GROUND BUSHING	2 2-1/2 3 DR 4	VARIES

8/21/02	SUPERCEDES DWG #818 DRAWN 4/21/81
DATE	REVISION
FOUNDATION FOR 34'-6" ARTERIAL STREET LIGHT OR TRAFFIC SIGNAL POLE - 3 OR 7 GAUGE WITH 15" BOLT CIRCLE	
CITY OF CHICAGO DEPT OF STREETS AND SANITATION BUREAU OF ELECTRICITY DIVISION OF ELECTRICAL ENGINEERING	
DRAFTSMAN B GARNSEY	ENTER DRAFTSMAN A CARTER
ELECTRICAL ENGINEER B GARNSEY	ENGINEER IN CHARGE B GARNSEY
DEPUTY COMMISSIONER B GARNSEY	DEPUTY COMMISSIONER B GARNSEY
SIZE 11 x 17	DATE 8/21/02

818



2nd ATTEMPT AT INTRODUCTION

09/14/2016

Alderman **Michael R. Zalewski**
Ward # 23
City of Chicago
City Hall, Room 200
121 North LaSalle Street
Chicago, Illinois 60602

Re: An ordinance to use and maintain a portion of the public right-of-way for **one (1) occupation of space(s)** for **Verizon Wireless**, adjacent to the premises known as **5219 S. Newcastle Ave.**.

Dear Alderman **Michael R. Zalewski**:

The applicant referenced above has requested the use of the public right-of-way for a **occupation of space(s)**. An ordinance has been prepared by the Department of Business Affairs and Consumer Protection – Small Business Center - Public Way Use Unit for presentation to the City Council. Because this request was made for properties located in your ward, as approved by you as per the attached, I respectfully request that you introduce the attached ordinance at the next City Council meeting.

If you have any questions regarding this ordinance, please contact Anthony Bertuca at (312) 744-5506.

Department of Business Affairs and Consumer Protection