



# City of Chicago



O2019-7314

Office of the City Clerk

## Document Tracking Sheet

<b>Meeting Date:</b>	9/18/2019
<b>Sponsor(s):</b>	Hopkins (2)
<b>Type:</b>	Ordinance
<b>Title:</b>	Grant(s) of privilege in public way for Matt Cerney
<b>Committee(s) Assignment:</b>	Committee on Transportation and Public Way

ORDINANCE  
MATT CERNEY  
Acct. No. 461077 - 1  
Permit No. 1141667

*Be It Ordained by the City Council of the City of Chicago:*

SECTION 1. Permission and authority are hereby given and granted to MATT CERNEY, upon the terms and subject to the conditions of this ordinance to maintain and use, as now constructed, one (1) Bay Window(s) projecting over the public right-of-way adjacent to its premises known as 2112 W. Le Moyne St..

Said Bay Window(s) at W. MOYNE STREET measure(s):

One (1) at eleven point one (11.1) feet in length, and twenty-four point one four (24.14) feet in width for a total of two hundred sixty-seven point nine five (267.95) square feet.

The location of said privilege shall be as shown on prints kept on file with the Department of Business Affairs and Consumer Protection and the Office of the City Clerk.

Said privilege shall be constructed in accordance with plans and specifications approved by the Department of Transportation (Division of Project Development).

This grant of privilege in the public way shall be subject to the provisions of Section 10-28-015 and all other required provisions of the Municipal Code of Chicago.

The grantee shall pay to the City of Chicago as compensation for the privilege #1141667 herein granted the sum of seventy-five (\$75.00) per annum in advance.

A 25% penalty will be added for payments received after due date.

The permit holder agrees to hold the City of Chicago harmless for any damage, relocation or replacement costs associated with damage, relocation or removal of private property caused by the City performing work in the public way.

Authority herein given and granted for a period of five (5) years from and after Date of Passage.

Alderman

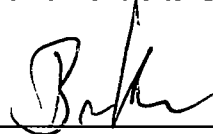

Brian Hopkins 2nd Ward

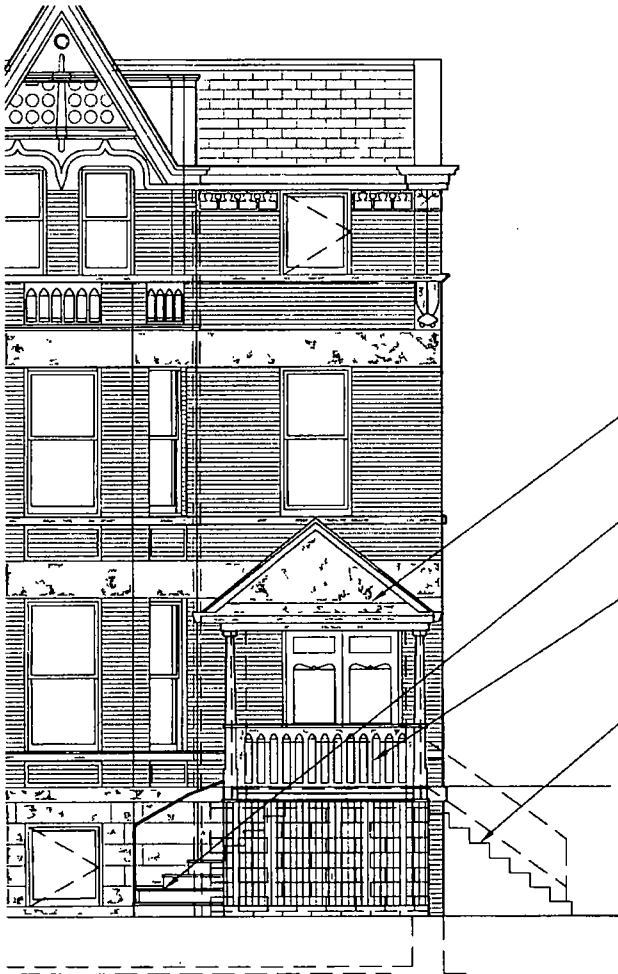
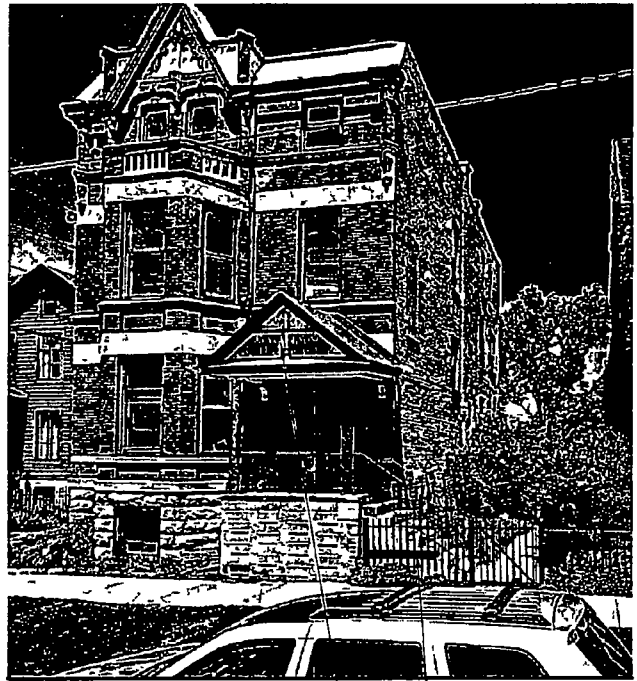
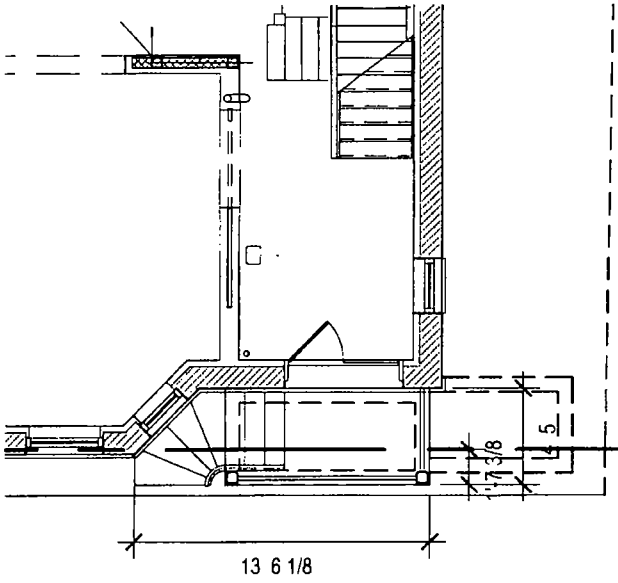

EXISTING CANOPY TO  
REMAIN

NEW STAIR TO  
MATCH HISTORIC  
STAIR

REPAIRED PORCH TO  
MATCH HISTORIC  
PORCH

EXISTING STAIR TO  
BE REMOVED



**09/18/2019**

Alderman **Brian Hopkins**  
Ward # **02**  
City of Chicago  
City Hall, Room **200**  
121 North LaSalle Street  
Chicago, Illinois 60602

Re: An ordinance to use and maintain a portion of the public right-of-way for **one (1) bay window(s)** for **MATT CERNEY**, adjacent to the premises known as **2112 W. Le Moyne St.**

Dear Alderman **Brian Hopkins**:

The applicant referenced above has requested the use of the public right-of-way for a **bay window(s)**. An ordinance has been prepared by the Department of Business Affairs and Consumer Protection – Small Business Center - Public Way Use Unit for presentation to the City Council. Because this request was made for properties located in your ward, as approved by you as per the attached, I respectfully request that you introduce the attached ordinance at the next City Council meeting.

If you have any questions regarding this ordinance, please contact Anthony Bertuca at (312) 744-5506.

**Department of Business Affairs and Consumer Protection**