



City of Chicago



O2015-4035

Office of the City Clerk Document Tracking Sheet

Meeting Date:	5/6/2015
Sponsor(s):	Waguespack (32)
Type:	Ordinance
Title:	Grant(s) of privilege in public way for PPF SS 2751 N Clybourn Ave
Committee(s) Assignment:	Committee on Transportation and Public Way

ORDINANCE
PPF SS 2751 NORTH CLYBOURN
Acct. No. 398121 - 1
Permit No. 1118625

Be It Ordained by the City Council of the City of Chicago:

SECTION 1. Permission and authority are hereby given and granted to PPF SS 2751 NORTH CLYBOURN, upon the terms and subject to the conditions of this ordinance to construct, install, maintain and use three (3) Door Swing(s) on the public right-of-way adjacent to its premises known as 2757 N. Clybourn Ave..

Said Door Swing(s) at N.Clybourn Avenue measure(s):

Three (3) at one (1) foot in length, and three (3) feet in width for a total of nine (9) square feet.

The location of said privilege shall be as shown on prints kept on file with the Department of Business Affairs and Consumer Protection and the Office of the City Clerk.

Said privilege shall be constructed in accordance with plans and specifications approved by the Department of Transportation (Division of Project Development).

This grant of privilege in the public way shall be subject to the provisions of Section 10-28-015 and all other required provisions of the Municipal Code of Chicago.

The grantee shall pay to the City of Chicago as compensation for the privilege #1118625 herein granted the sum of two hundred twenty-five (\$225.00) per annum in advance.

A 25% penalty will be added for payments received after due date.

The permit holder agrees to hold the City of Chicago harmless for any damage, relocation or replacement costs associated with damage, relocation or removal of private property caused by the City performing work in the public way.

Authority herein given and granted for a period of five (5) years from and after Date of Passage.

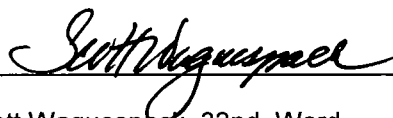
Alderman 
Scott Waguespack 32nd Ward

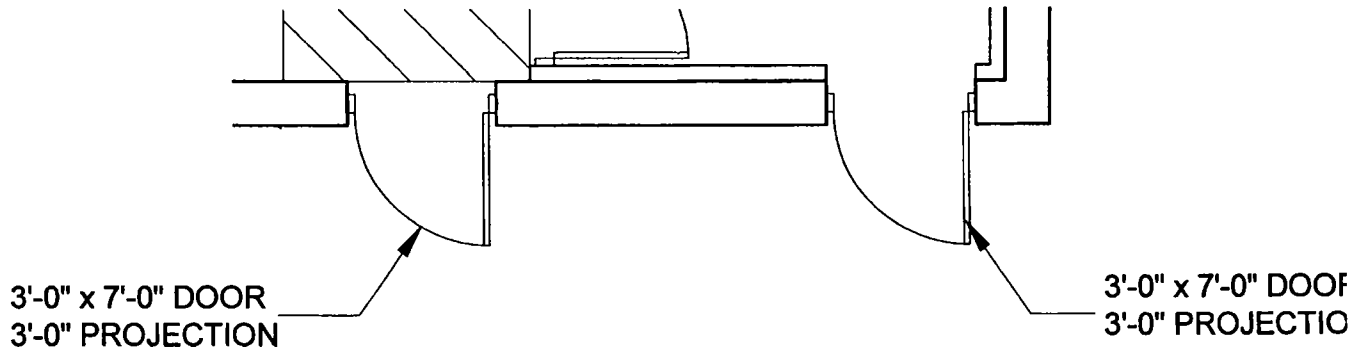

PLAN

1/4" = 1'-0"

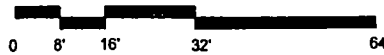

SAFEGUARD STORAGE
PROPERTIES, LLC
OWNER
05/01/2016

2757 N. CLYBOURN AVE.
CHICAGO, ILLINOIS

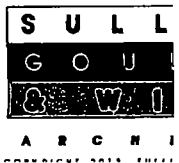



05/06/2015

Alderman **Scott Waguespack**
Ward # **32**
City of Chicago
City Hall, Room **300**
121 North LaSalle Street
Chicago, Illinois 60602

Re: An ordinance to use and maintain a portion of the public right-of-way for **three (3) door swing(s)** for **PPF SS 2751 NORTH CLYBOURN**, adjacent to the premises known as **2757 N. Clybourn Ave.**.

Dear Alderman **Scott Waguespack**:

The applicant referenced above has requested the use of the public right-of-way for a **door swing(s)**. An ordinance has been prepared by the Department of Business Affairs and Consumer Protection – Small Business Center - Public Way Use Unit for presentation to the City Council. Because this request was made for properties located in your ward, as approved by you as per the attached, I respectfully request that you introduce the attached ordinance at the next City Council meeting.

If you have any questions regarding this ordinance, please contact Anthony Bertuca at (312) 744-5506.

Department of Business Affairs and Consumer Protection