



Office of the City Clerk



O2013-959

Office of the City Clerk

City Council Document Tracking Sheet

| | |
|---------------------------------|--|
| Meeting Date: | 2/13/2013 |
| Sponsor(s): | Harris, Michelle A. (8) |
| Type: | Ordinance |
| Title: | Grant(s) of privilege in public way for Veja Enterprise LLC - tree grates |
| Committee(s) Assignment: | Committee on Transportation and Public Way |

ORDINANCE
VEJA ENTERPRISE LLC
Acct. No. 375503 - 1
Permit No. 1102885

Be It Ordained by the City Council of the City of Chicago:

SECTION 1. Permission and authority are hereby given and granted to VEJA ENTERPRISE LLC, upon the terms and subject to the conditions of this ordinance to construct, install, maintain and use one (1) Tree Grates(s) on the public right-of-way adjacent to its premises known as 8501 S. Cottage Grove Ave..

Said Tree Grates(s) at S. Cottage Grove measure(s):

One (1) at five (5) feet in length, and five (5) feet in width for a total of twenty-five (25) square feet.

The location of said privilege shall be as shown on prints kept on file with the Department of Business Affairs and Consumer Protection and the Office of the City Clerk.

Said privilege shall be constructed in accordance with plans and specifications approved by the Department of Planning and Development and Department of Transportation (Division of Project Development).

This grant of privilege in the public way shall be subject to the provisions of Section 10-28-015 and all other required provisions of the Municipal Code of Chicago.

The grantee shall pay to the City of Chicago as compensation for the privilege #1102885 herein granted the sum of zero (\$0.00) per annum in advance.

A 25% penalty will be added for payments received after due date.

The permit holder agrees to hold the City of Chicago harmless for any damage, relocation or replacement costs associated with damage, relocation or removal of private property caused by the City performing work in the public way.

Authority herein given and granted for a period of five (5) years from and after Date of Passage.

Alderman  _____

Michelle A. Harris 8th Ward

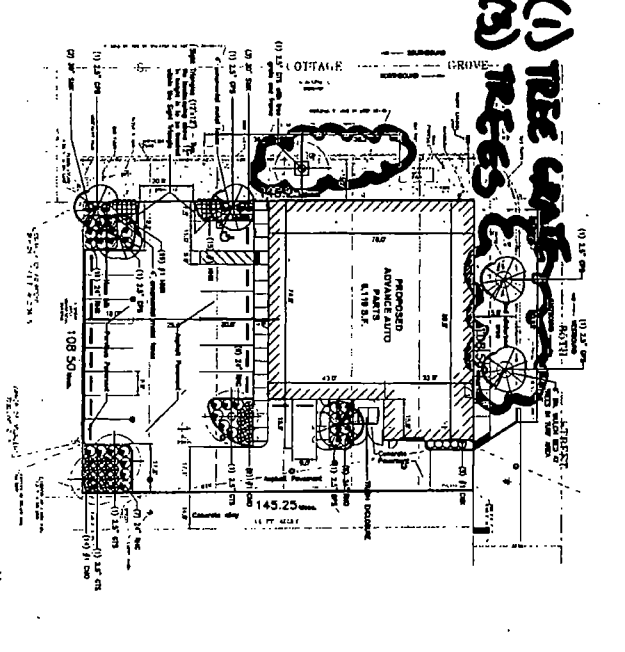
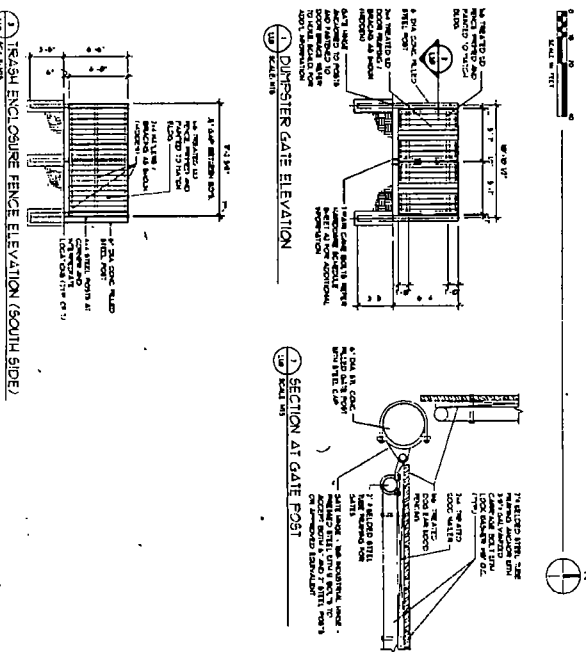
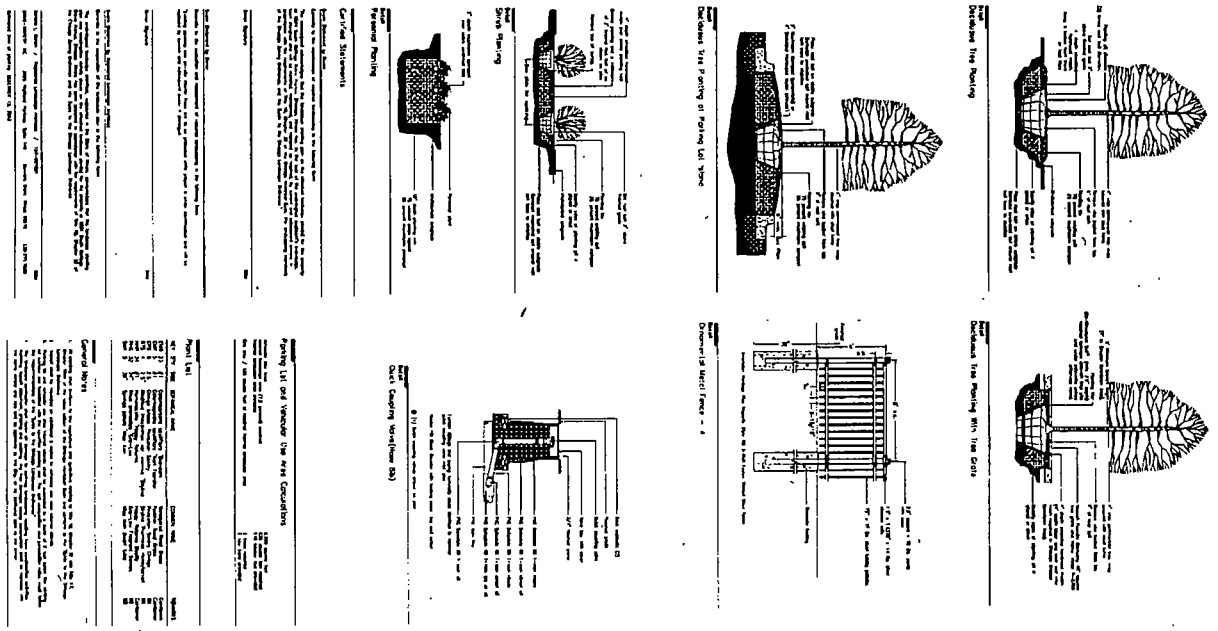

| | LANDSCAPE DEVELOPMENT PLAN L10 | Advance Auto Parts STORE # - 7184 DEVELOPER GRANITE ASSET MANAGEMENT SERVICES | 8501 S. COITAGE GROVE AVE. CHICAGO, IL | SHIVE-HATTERY ARCHITECTURE • ENGINEERING 3025 Highland Parkway, Ste 140 Downers Grove, Illinois 60115 630.271.7800 fax 630.241.4078 shive-hattery.com Iowa Illinois Missouri Other Firm Number: 154-000214 | | | | | | | | | | | | | | | | | | | | | | | | | | | | | | | |
|-----|---|--|---|---|-----|----------|--|-----|--|--|-----|--|--|-----|--|--|-----|--|--|-----|--|--|-----|--|--|-----|--|--|-----|--|--|-----|--|--|---|
| | REVISIONS <table border="1"> <thead> <tr> <th>NO.</th> <th>DATE</th> <th>DESCRIPTION</th> </tr> </thead> <tbody> <tr> <td>001</td> <td>08-11-10</td> <td>REVISED FOR CITY LANDSCAPE CITY REVIEW</td> </tr> <tr> <td>002</td> <td></td> <td></td> </tr> <tr> <td>003</td> <td></td> <td></td> </tr> <tr> <td>004</td> <td></td> <td></td> </tr> <tr> <td>005</td> <td></td> <td></td> </tr> <tr> <td>006</td> <td></td> <td></td> </tr> <tr> <td>007</td> <td></td> <td></td> </tr> <tr> <td>008</td> <td></td> <td></td> </tr> <tr> <td>009</td> <td></td> <td></td> </tr> <tr> <td>010</td> <td></td> <td></td> </tr> </tbody> </table> | NO. | DATE | DESCRIPTION | 001 | 08-11-10 | REVISED FOR CITY LANDSCAPE CITY REVIEW | 002 | | | 003 | | | 004 | | | 005 | | | 006 | | | 007 | | | 008 | | | 009 | | | 010 | | | PROJECT NO. DATE OF PREPARATION SCALE |
| NO. | DATE | DESCRIPTION | | | | | | | | | | | | | | | | | | | | | | | | | | | | | | | | | |
| 001 | 08-11-10 | REVISED FOR CITY LANDSCAPE CITY REVIEW | | | | | | | | | | | | | | | | | | | | | | | | | | | | | | | | | |
| 002 | | | | | | | | | | | | | | | | | | | | | | | | | | | | | | | | | | | |
| 003 | | | | | | | | | | | | | | | | | | | | | | | | | | | | | | | | | | | |
| 004 | | | | | | | | | | | | | | | | | | | | | | | | | | | | | | | | | | | |
| 005 | | | | | | | | | | | | | | | | | | | | | | | | | | | | | | | | | | | |
| 006 | | | | | | | | | | | | | | | | | | | | | | | | | | | | | | | | | | | |
| 007 | | | | | | | | | | | | | | | | | | | | | | | | | | | | | | | | | | | |
| 008 | | | | | | | | | | | | | | | | | | | | | | | | | | | | | | | | | | | |
| 009 | | | | | | | | | | | | | | | | | | | | | | | | | | | | | | | | | | | |
| 010 | | | | | | | | | | | | | | | | | | | | | | | | | | | | | | | | | | | |



Department of Business Affairs and Consumer Protection
Business Assistance Center - Public Way Use Unit
City Hall - 121 N. LaSalle Street, Room 800 • Chicago, IL 60602
(312)-74-GOBIZ (312-744-6249) • (312) 744-1944 (TTY)
<http://www.cityofchicago.org/bacp>

2nd ATTEMPT AT INTRODUCTION

02/13/2013

Alderman **Michelle A. Harris**
Ward # 08
City of Chicago
City Hall, Room 300
121 North LaSalle Street
Chicago, Illinois 60602

Re: An ordinance to use and maintain a portion of the public right-of-way for **one (1) tree grates(s)** for **VEJA ENTERPRISE LLC**, adjacent to the premises known as **8501 S. Cottage Grove Ave.**.

Dear Alderman **Michelle A. Harris**:

The applicant referenced above has requested the use of the public right-of-way for a **tree grates(s)**. An ordinance has been prepared by the Department of Business Affairs and Consumer Protection – Business Assistance Center - Public Way Use Unit for presentation to the City Council. Because this request was made for properties located in your ward, as approved by you as per the attached, I respectfully request that you introduce the attached ordinance at the next City Council meeting.

If you have any questions regarding this ordinance, please contact Anthony Bertuca at (312) 744-5506.

Department of Business Affairs and Consumer Protection