



City of Chicago



O2015-1965

Office of the City Clerk

Document Tracking Sheet

Meeting Date:	3/18/2015
Sponsor(s):	Burnett (27)
Type:	Ordinance
Title:	Grant(s) of privilege in public way for Butterfly Sushi & Thai Cuisine on Chicago Ave.
Committee(s) Assignment:	Committee on Transportation and Public Way

ORDINANCE
BUTTERFLY SUSHI & THAI CUISINE ON CHICAGO AVE
Acct. No. 336656 - 1
Permit No. 1116921

Be It Ordained by the City Council of the City of Chicago:

SECTION 1. Permission and authority are hereby given and granted to BUTTERFLY SUSHI & THAI CUISINE ON CHICAGO AVE, upon the terms and subject to the conditions of this ordinance to maintain and use one (1) sign(s) projecting over the public right-of-way attached to its premises known as 1421 W. Chicago Ave..

Said sign structure(s) measures as follows; along W CHICAGO AVE:
One (1) at three point three three (3.33) feet in length, three point three three (3.33) feet in height and nine (9) feet above grade level.

The location of said privilege shall be as shown on prints kept on file with the Department of Business Affairs and Consumer Protection and the Office of the City Clerk.

Said privilege shall be constructed in accordance with plans and specifications approved by the Department of Transportation (Division of Project Development) and Zoning Department - Signs.

This grant of privilege in the public way shall be subject to the provisions of Section 10-28-015 and all other required provisions of the Municipal Code of Chicago.

The grantee shall pay to the City of Chicago as compensation for the privilege #1116921 herein granted the sum of one hundred (\$100.00) per annum in advance.

A 25% penalty will be added for payments received after due date.

The permit holder agrees to hold the City of Chicago harmless for any damage, relocation or replacement costs associated with damage, relocation or removal of private property caused by the City performing work in the public way.

Authority herein given and granted for a period of five (5) years from and after 04/22/2014.

Alderman 

Walter Burnett Jr. 27th Ward

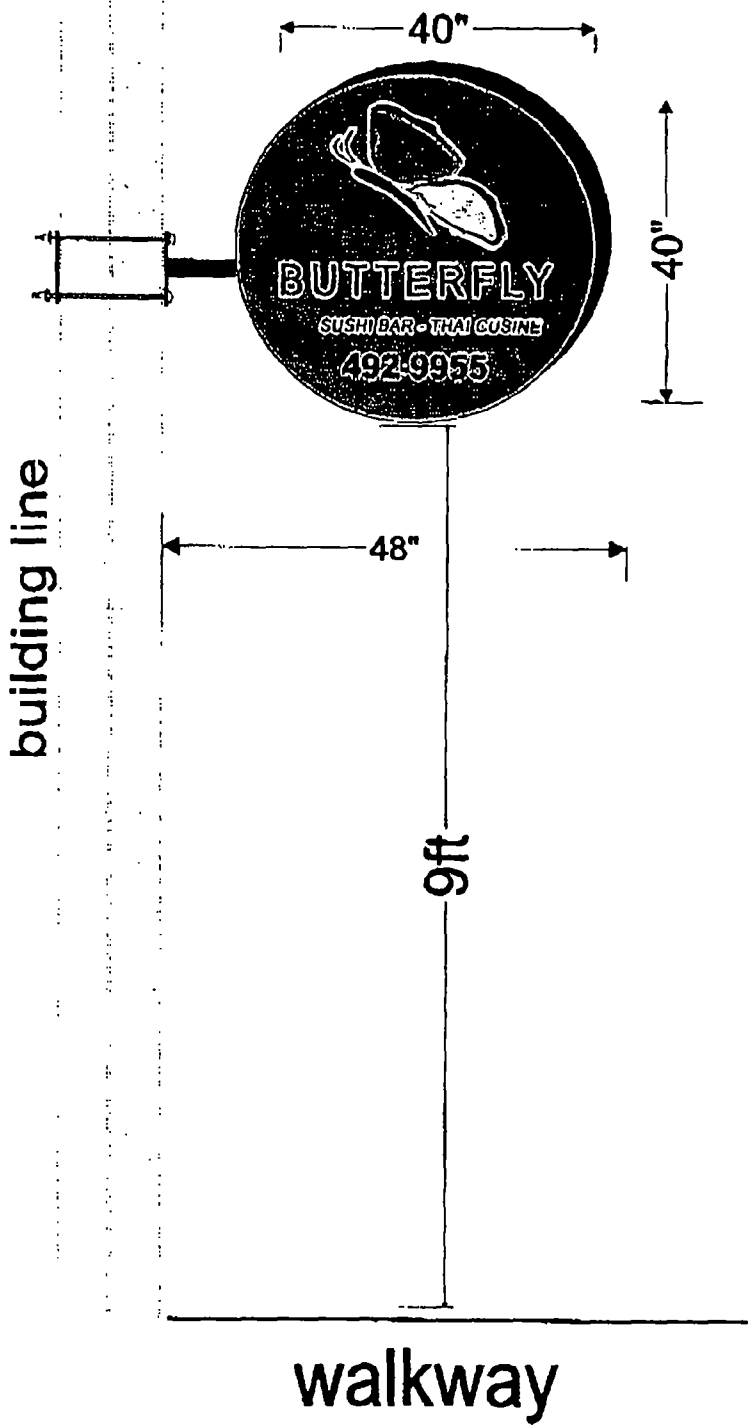
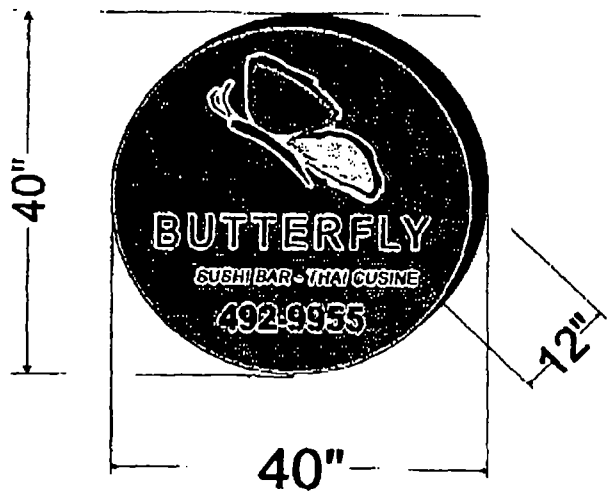

NEON
EXPRESS SIGNS Inc.
Whole Sale & Retail Interior / Exterior Signage
www.neonexpress.net

1-888-2NEONEX
2819 W. Montrose Chicago, IL 60618
5028 N. Broadway Chicago, IL 60640

CUSTOMER: Restaurant Butterfly
LOCATION: 1421 W. Chicago Ave.
Chicago, IL 60642

Design By: CN
Date: 10/01/08