



City of Chicago



O2014-2900

Office of the City Clerk

Document Tracking Sheet

Meeting Date:	4/2/2014
Sponsor(s):	Tunney (44)
Type:	Ordinance
Title:	Grant(s) of privilege in public way for Starbucks
Committee(s) Assignment:	Committee on Transportation and Public Way

ORDINANCE
STARBUCKS

Acct. No. 63414 - 163

Permit No. 1111194

ORDINANCE
STARBUCKS

Acct. No. 63414 - 163

Permit No. 1111194

Be It Ordained by the City Council of the City of Chicago:

City Council of the City of Chicago

SECTION 1. Permission and authority are hereby given and granted to STARBUCKS, upon the terms and subject to the conditions of this ordinance to construct, install, maintain and use two (2) Light Fixture(s) projecting over the public right-of-way adjacent to its premises known as 3824 N. Southport Ave..

Said Light Fixture(s) at N. Southport Avenue measure(s):
Two (2) at point five (.5) feet in length, point five (.5) feet in width and ten (10) feet above grade level.

The location of said privilege shall be as shown on prints kept on file with the Department of Business Affairs and Consumer Protection and the Office of the City Clerk.

Said privilege shall be constructed in accordance with plans and specifications approved by the Department of Transportation (Division of Project Development).

This grant of privilege in the public way shall be subject to the provisions of Section 10-28-015 and all other required provisions of the Municipal Code of Chicago.

The grantee shall pay to the City of Chicago as compensation for the privilege #1111194 herein granted the sum of twenty-five (\$25.00) per annum in advance.

A 25% penalty will be added for payments received after due date.

The permit holder agrees to hold the City of Chicago harmless for any damage, relocation or replacement costs associated with damage, relocation or removal of private property caused by the City performing work in the public way.

Authority herein given and granted for a period of five (5) years from and after Date of Passage.

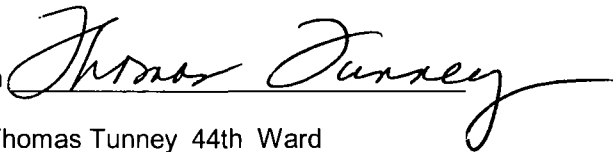
Alderman 
Thomas Tunney 44th Ward

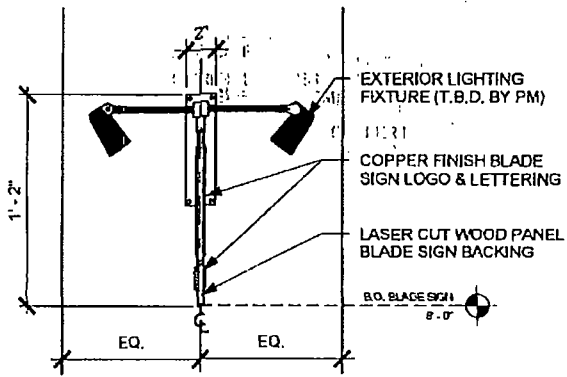

2 BLADE SIGN DETAIL (SIDE VIEW)
Scale: 1 1/2" = 1'-0"

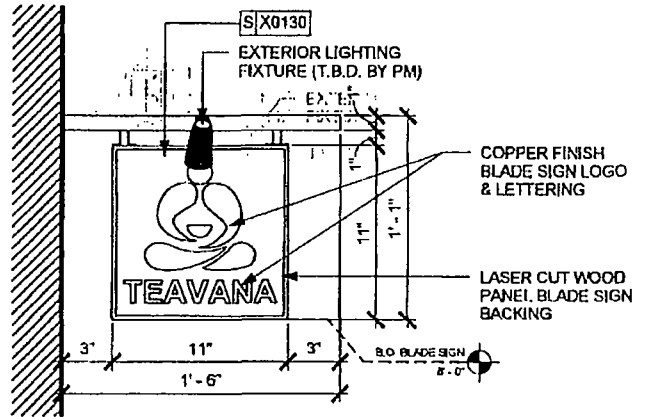

3 BLADE SIGN DETAIL (ELEVATION)
Scale: 1 1/2" = 1'-0"

SIGNAGE SCHEDULE - "S"				
DESIGN ID	COUNT	DESCRIPTION	RESP.	COMMENTS
SIGNAGE				