



# City of Chicago



O2015-7549

Office of the City Clerk

## Document Tracking Sheet

<b>Meeting Date:</b>	10/14/2015
<b>Sponsor(s):</b>	Reilly (42)
<b>Type:</b>	Ordinance
<b>Title:</b>	Grant(s) of privilege in public way for Roanoke Hospitality LLC
<b>Committee(s) Assignment:</b>	Committee on Transportation and Public Way

ORDINANCE  
ROANOKE HOSPITALITY, LLC  
Acct. No. 398305 - 2  
Permit No. 1120280

*Be It Ordained by the City Council of the City of Chicago:*

SECTION 1. Permission and authority are hereby given and granted to ROANOKE HOSPITALITY, LLC, upon the terms and subject to the conditions of this ordinance to construct, install, maintain and use two (2) Light Fixture(s) projecting over the public right-of-way adjacent to its premises known as 135 W. Madison St..

Said Light Fixture(s) at W. Madison Street measure(s):

Two (2) at point seven five (.75) feet in length, one point six two (1.62) foot in width and ten point eight three (10.83) feet above grade level.

The location of said privilege shall be as shown on prints kept on file with the Department of Business Affairs and Consumer Protection and the Office of the City Clerk.

Said privilege shall be constructed in accordance with plans and specifications approved by the Department of Transportation (Division of Project Development).

This grant of privilege in the public way shall be subject to the provisions of Section 10-28-015 and all other required provisions of the Municipal Code of Chicago.

The grantee shall pay to the City of Chicago as compensation for the privilege #1120280 herein granted the sum of eighty (\$80.00) per annum in advance.

A 25% penalty will be added for payments received after due date.

The permit holder agrees to hold the City of Chicago harmless for any damage, relocation or replacement costs associated with damage, relocation or removal of private property caused by the City performing work in the public way.

Authority herein given and granted for a period of five (5) years from and after Date of Passage.

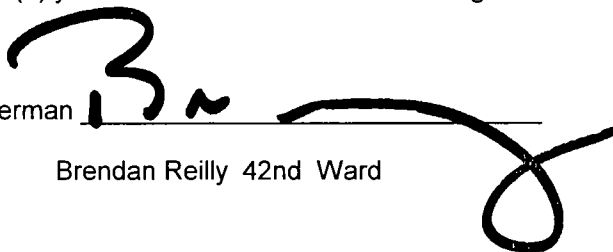
Alderman   
Brendan Reilly 42nd Ward

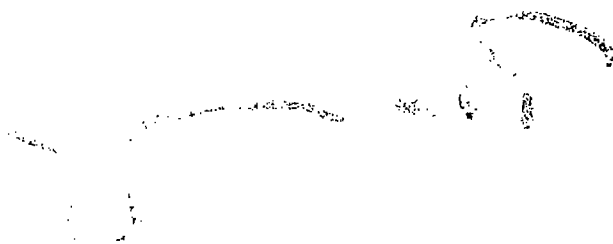

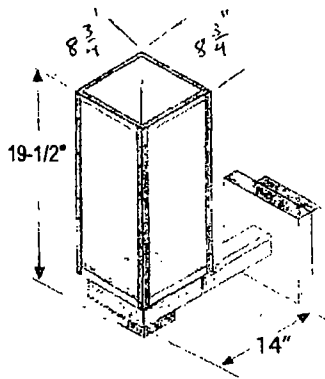

Wall Mount



IMAGE OF GAS LAMP FIXTURE (SKU 04800743 NG)

**G1 G2** WALL MOUNTED GAS LAMP FIXTURES SCALE 1/2" = 1'-0"

**GENERAL SPECIFICATION**

WALL MOUNTED GAS LAMP FIXTURES BY TRAVIS INDUSTRIES, INC.  
 (WALL MOUNT - NO RAINCAP)  
 (SKU 04800743 TO BE USED WITH SKU 04800743 NG FIXTURE)  
 FIXTURES TO BE PROVIDED BY CHANDLER SIGN and INSTALLED BY GENERAL CONTRACTOR

02101040

MEMBER ORIEL (revised)

01070000

Sheet 4 of 5

11 CASALE ST  
 CHICAGO IL 60620

Account: DORFMS

Designer: J. HODDLESTON

Date: 03/20/15

ASSTY/DESIGN

Client:

Estimate:

Contracting:

Architect:

Engineer:

Landscaper:

Chandler Signs

CHANDLER SIGNS

11 CASALE ST  
 CHICAGO IL 60620

Phone: (773) 326-1111

Fax: (773) 326-1112

Website: www.chandler-signs.com

© 2015 Chandler Signs