



# City of Chicago



O2015-8800

Office of the City Clerk

## Document Tracking Sheet

<b>Meeting Date:</b>	12/9/2015
<b>Sponsor(s):</b>	Reilly (42)
<b>Type:</b>	Ordinance
<b>Title:</b>	Grant(s) of privilege in public way for Imperial Lamian
<b>Committee(s) Assignment:</b>	Committee on Transportation and Public Way

ORDINANCE  
IMPERIAL LAMIAN  
Acct. No. 399098 - 1  
Permit No. 1120375

*Be It Ordained by the City Council of the City of Chicago:*

SECTION 1. Permission and authority are hereby given and granted to IMPERIAL LAMIAN, upon the terms and subject to the conditions of this ordinance to construct, install, maintain and use ten (10) Light Fixture(s) projecting over the public right-of-way adjacent to its premises known as 6 W. Hubbard St..

Said Light Fixture(s) at N. State Street measure(s):

Seven (7) at one point one seven (1.17) foot in length, point five eight (.58) feet in width and seven point five (7.5) feet above grade level.

Said Light Fixture(s) at W. Hubbard Street measure(s):

Three (3) at one point one seven (1.17) foot in length, point five eight (.58) feet in width and seven point five (7.5) feet above grade level.

The location of said privilege shall be as shown on prints kept on file with the Department of Business Affairs and Consumer Protection and the Office of the City Clerk.

Said privilege shall be constructed in accordance with plans and specifications approved by the Department of Transportation (Division of Project Development).

This grant of privilege in the public way shall be subject to the provisions of Section 10-28-015 and all other required provisions of the Municipal Code of Chicago.

The grantee shall pay to the City of Chicago as compensation for the privilege #1120375 herein granted the sum of twenty-five (\$25.00) per annum in advance.

A 25% penalty will be added for payments received after due date.

The permit holder agrees to hold the City of Chicago harmless for any damage, relocation or replacement costs associated with damage, relocation or removal of private property caused by the City performing work in the public way.

Authority herein given and granted for a period of five (5) years from and after Date of Passage.

Alderman

  
Brendan Reilly 42nd Ward

# LIGHT FIXTURE DIMENSIONS

(LOCATED ON BOTH W. HUBBARD AND N. STATE)

\*LIGHTS WILL HAVE DIMMING CAPABILITIES

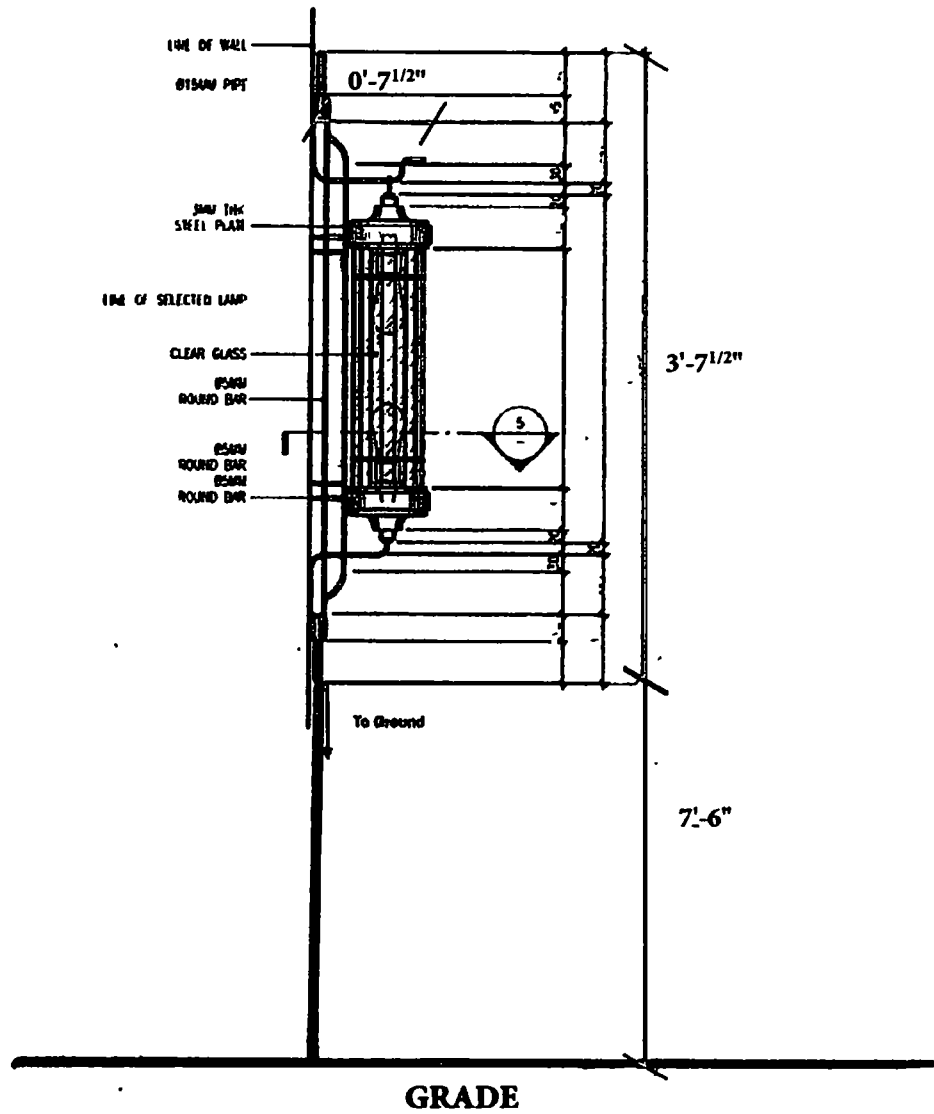

ACCT #399098  
IMPERIAL LA MIAN CHICAGO, LLC  
d/b/a IMPERIAL LAMIAN  
6 W HUBBARD STREET  
CHICAGO IL 60654