



City of Chicago



O2021-1370

Office of the City Clerk

Document Tracking Sheet

Meeting Date:	4/21/2021
Sponsor(s):	Tunney (44)
Type:	Ordinance
Title:	Awning(s) for Iconic Optical, Inc.
Committee(s) Assignment:	Committee on Transportation and Public Way

ORDINANCE
ICONIC OPTICAL INC.
Acct. No. 397977 - 1
Permit No. 1148245

Be It Ordained by the City Council of the City of Chicago:

SECTION 1. Permission and authority are hereby given and granted to ICONIC OPTICAL INC., upon the terms and subject to the conditions of this ordinance to maintain and use, as now constructed, one (1) Awning(s) projecting over the public right-of-way adjacent to its premises known as 2915 N. Broadway .

Said Awning(s) at N Broadway measure(s):

One (1) at twelve (12) feet in length, and one point five (1.5) foot in width for a total of eighteen (18) square feet.

The location of said privilege shall be as shown on prints kept on file with the Department of Business Affairs and Consumer Protection and the Office of the City Clerk.

Said privilege shall be constructed in accordance with plans and specifications approved by the Zoning Department - Signs.

This grant of privilege in the public way shall be subject to the provisions of Section 10-28-015 and all other required provisions of the Municipal Code of Chicago.

The grantee shall pay to the City of Chicago as compensation for the privilege #1148245 herein granted the sum of fifty (\$50.00) per annum in advance.

A 25% penalty will be added for payments received after due date.

The permit holder agrees to hold the City of Chicago harmless for any damage, relocation or replacement costs associated with damage, relocation or removal of private property caused by the City performing work in the public way.

Authority herein given and granted for a period of five (5) years from and after 03/16/2021.

Alderman _____

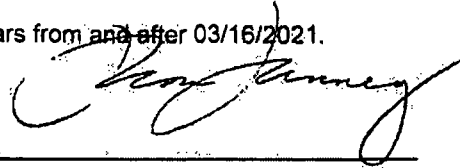

Thomas Tunney 44th Ward

AWNING SIGN

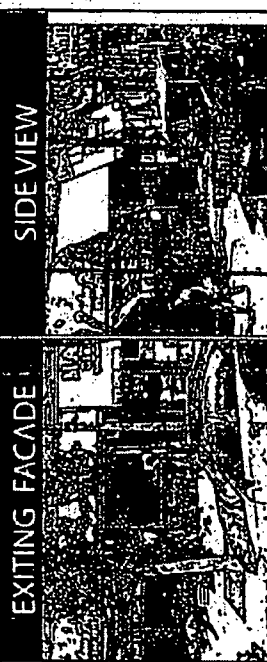
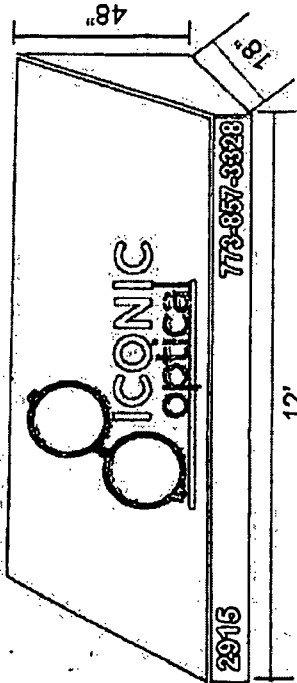
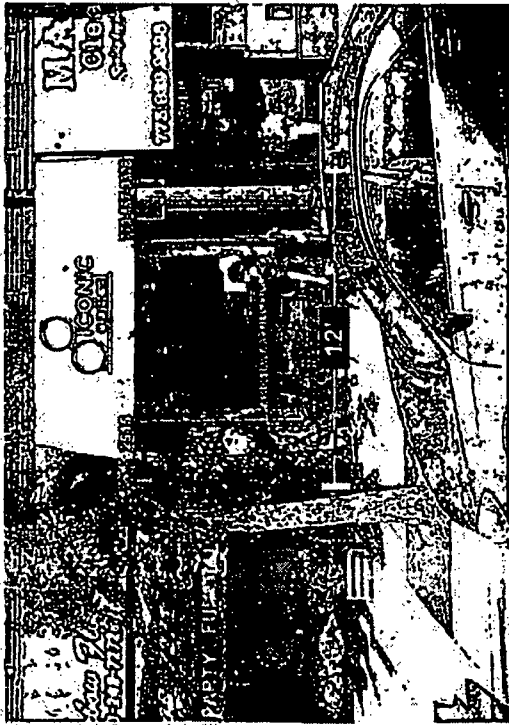

SPECIFICATIONS

- 1 Awning Fabric Material
- 2 1" X 1" SQUARE TUBE FRAME
- 3 3/16" GALVANIZED STEEL Z-CLIP ATTACHMENT
- 4 APPROPRIATE NON-CORROSIVE WALL FASTENER SEE MOUNTING OPTION DETAILS
- 5 #12 TEK SCREW

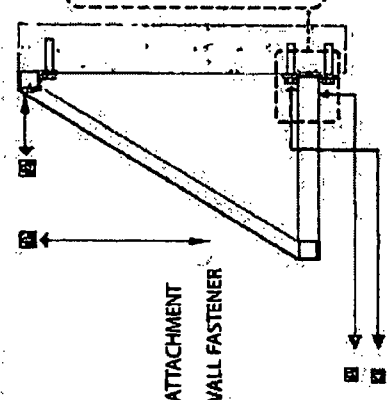

COLOR SELECTION

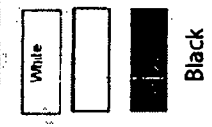

MOUNTING DETAIL

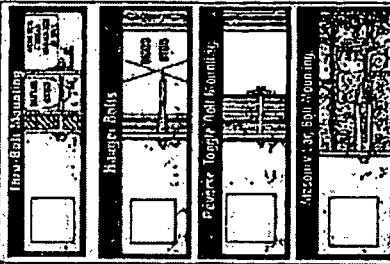

31 (Bridgeport)
Chicago, IL

3401 S Halsted St.
Chicago, IL 60608

773-847-2828
Fax 773-847-0088

BRIDGEPORT

PASTY

SIGN ELEVATION

EXHIBIT

Address: 2915 N Broadway
Chicago, IL

City: Chicago, IL

State: IL

Account Rep: K. WONG

Sales Rep: K. WONG

APPROVALS: _____

CLIENT: _____

DESIGN: _____

PROJ: _____

Designer: K. WONG

Design No: _____

DATE: 07-27-13

Rev Date: _____

The purchaser agrees to hold the contractor harmless for any claims, damages, or liabilities, including attorney's fees, which may occur as a result of the contractor's design and construction. The contractor shall be responsible for obtaining all necessary permits and licenses for the project.

THIS DESIGN AND ENGINEERING IS SUBMITTED AS OUR PROPOSAL, AND THE RIGHT TO USE OR EXHIBIT IN ANY FORM, IS NOT AUTHORIZED WITHOUT WRITTEN PERMISSION BY MONSTRIC, INC.



Department of Business Affairs and Consumer Protection
Small Business Center - Public Way Use Unit
City Hall - 121 N. LaSalle Street, Room 800 • Chicago, IL 60602
312-74-GOBIZ / 312-744-6249 • (312) 744-1944 (TTY)
<http://www.cityofchicago.org/bacp>

04/21/2021

Alderman Thomas Tunney
Ward # 44
City of Chicago
City Hall, Room 300
121 North LaSalle Street
Chicago, Illinois 60602

**Re: An ordinance to use and maintain a portion of the public right-of-way for one (1) awning(s) for
ICONIC OPTICAL INC., adjacent to the premises known as 2915 N. Broadway .**

Dear Alderman Thomas Tunney:

The applicant referenced above has requested the use of the public right-of-way for a **awning(s)**. An ordinance has been prepared by the Department of Business Affairs and Consumer Protection – Small Business Center - Public Way Use Unit for presentation to the City Council. Because this request was made for properties located in your ward, as approved by you as per the attached, I respectfully request that you introduce the attached ordinance at the next City Council meeting.

If you have any questions regarding this ordinance, please contact Anthony Bertuca at (312) 744-5506.

Department of Business Affairs and Consumer Protection