



# City of Chicago



O2019-7909

Office of the City Clerk

## Document Tracking Sheet

<b>Meeting Date:</b>	10/10/2019
<b>Sponsor(s):</b>	Tunney (44)
<b>Type:</b>	Ordinance
<b>Title:</b>	Grant(s) of privilege in public way for BBU Spa
<b>Committee(s) Assignment:</b>	Committee on Transportation and Public Way

Direct Intro  
# 44

ORDINANCE  
BBU SPA  
Acct. No. 417996 - 1  
Permit No. 1131230

*Be It Ordained by the City Council of the City of Chicago:*

SECTION 1. Permission and authority are hereby given and granted to BBU SPA, upon the terms and subject to the conditions of this ordinance to maintain and use one (1) sign(s) projecting over the public right-of-way attached to its premises known as 3021 N. Broadway .

Said sign structure(s) measures as follows; along N. Broadway:  
One (1) at four (4) feet in length, two (2) feet in height and twelve (12) feet above grade level.

The location of said privilege shall be as shown on prints kept on file with the Department of Business Affairs and Consumer Protection and the Office of the City Clerk.

Said privilege shall be constructed in accordance with plans and specifications approved by the Department of Transportation (Division of Project Development) and Zoning Department - Signs.

This grant of privilege in the public way shall be subject to the provisions of Section 10-28-015 and all other required provisions of the Municipal Code of Chicago.

The grantee shall pay to the City of Chicago as compensation for the privilege #1131230 herein granted the sum of one hundred (\$100.00) per annum in advance.

A 25% penalty will be added for payments received after due date.

The permit holder agrees to hold the City of Chicago harmless for any damage, relocation or replacement costs associated with damage, relocation or removal of private property caused by the City performing work in the public way.

Authority herein given and granted for a period of five (5) years from and after Date of Passage.

Alderman \_\_\_\_\_

Thomas Tunney 44<sup>th</sup> Ward

# Internally Illuminated Box Sign

**CROSS SECTION DETAIL**

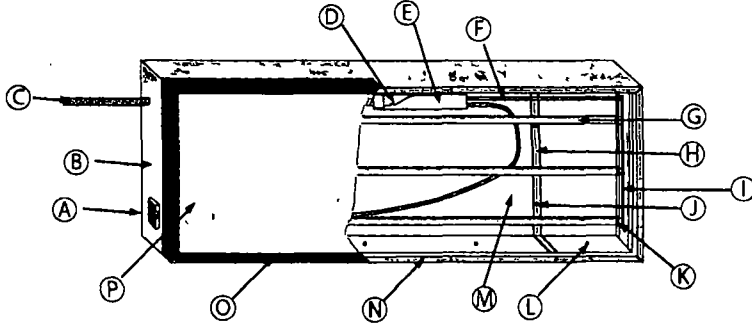

A	listed disconnect switch
B	Aluminum side
C	primary electrical source
D	H <sub>0</sub> Ballast
E	Ballast box
F	1/2 greenfield
G	Flourescent Lamp
H	1 1/2 x 1 1/2 x 3/16 U Steel Angle
I	Wire way box
J	Installation Holes
K	Socket
L	Weap Holes
M	o8o Sheet Metal Back
N	1 1/2 x 1 1/2 x 1/8" Steel Angle
O	2' x 2 Aluminum Retainers
P	3/16 White Lexon

All electrical to be UL Listed

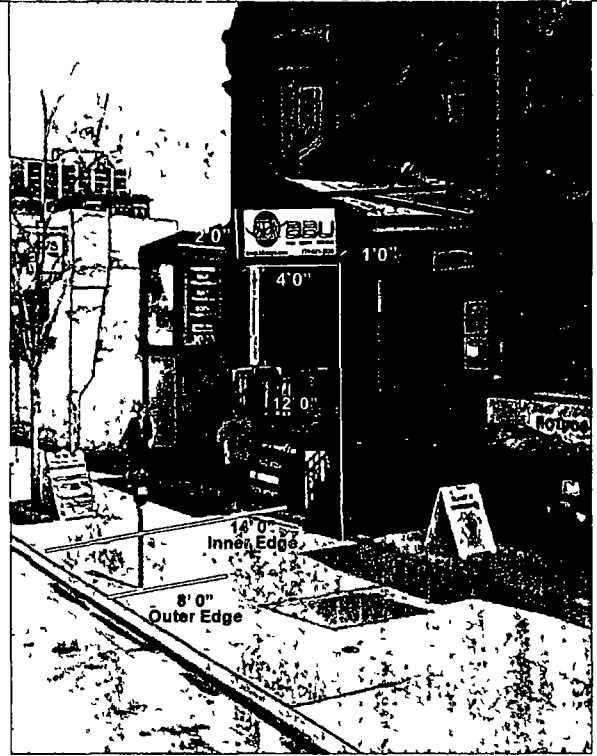

NOTE Photo for representational purposes only Signs are not to scale and may appear larger or smaller than shown

Sign Erector	Location	Description
<b>PRO IMAGE</b> 1547 W. Chicago, Ave. Chicago, IL 60642 Tel. 773 292 1111 Fax. 773 645 4169	<b>West Elevation</b> Address 3021 N Broadway Chicago, IL 60657	- NEW PROJECTING BOX ILLUMINATE SIGN - WALL MOUNTED - VINYL LETTERING - 3/16 WHITE LEXON - INTERNALLY ILLUMINATE 3 FT FLOURESCENT LAMPS - READS SPA BBU
	Date 1-17-2018	Client <b>SPA BBU</b>



Department of Business Affairs and Consumer Protection  
Small Business Center - Public Way Use Unit  
City Hall - 121 N. LaSalle Street, Room 800 • Chicago, IL 60602  
312-74-GOBIZ / 312-744-6249 • (312) 744-1944 (TTY)  
<http://www.cityofchicago.org/bacp>

09/18/2019

Alderman **Thomas Tunney**  
Ward # **44**  
City of Chicago  
City Hall, Room **300**  
121 North LaSalle Street  
Chicago, Illinois 60602

Re: An ordinance to use and maintain a portion of the public right-of-way for **one (1) sign(s)** for **BBU SPA**, adjacent to the premises known as **3021 N. Broadway**.

Dear Alderman **Thomas Tunney**:

The applicant referenced above has requested the use of the public right-of-way for a **sign(s)**. An ordinance has been prepared by the Department of Business Affairs and Consumer Protection – Small Business Center - Public Way Use Unit for presentation to the City Council. Because this request was made for properties located in your ward, as approved by you as per the attached, I respectfully request that you introduce the attached ordinance at the next City Council meeting.

If you have any questions regarding this ordinance, please contact Anthony Bertuca at (312) 744-5506.

**Department of Business Affairs and Consumer Protection**