



# City of Chicago



O2021-4996

Office of the City Clerk

## Document Tracking Sheet

<b>Meeting Date:</b>	11/17/2021
<b>Sponsor(s):</b>	Reilly (42)
<b>Type:</b>	Ordinance
<b>Title:</b>	Grant(s) of privilege in public way for BHLDN
<b>Committee(s) Assignment:</b>	Committee on Transportation and Public Way

ORDINANCE

BHLDN

Acct. No.: 366429 - 1

Permit No: BACP1599644

*Be It Ordained by the City Council of the City of Chicago:*

SECTION 1. Permission and authority are hereby given and granted to BHLDN upon the terms and subject to the conditions of this ordinance to maintain and use, as now constructed, four (4) Light Fixture(s) projecting over the public right-of-way adjacent to its premises known as 8 E WALTON ST.

Said Light Fixture(s) at E. Walton measure(s):

Four (4) at zero point six six (0.66) feet in length, Zero (0) feet in width and fifteen point five (15.5) feet above grade level.

The location of said privilege shall be as shown on prints kept on file with the Department of Business Affairs and Consumer Protection and the Office of the City Clerk.

Said privilege shall be constructed in accordance with plans and specifications approved by the Department of Transportation (Division of Project Development).

This grant of privilege in the public way shall be subject to the provisions of Section 10-28-015 and all other required provisions of the Municipal Code of Chicago:

The grantee shall pay to the City of Chicago as compensation for the privilege #BACP1599644 herein granted the sum of ninety (\$90.00) per annum in advance.

A 25% penalty will be added for payments received after due date.

The permit holder agrees to hold the City of Chicago harmless for any damage, relocation or replacement costs associated with damage, relocation or removal of private property caused by the City performing work in the public way.

Authority herein given and granted for a period of five (5) years from and after 11/02/2021.

Alderman:

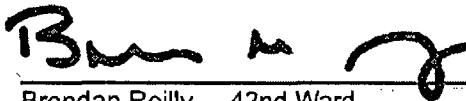

Brendan Reilly 42nd Ward

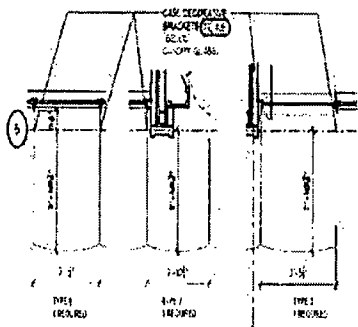

2 CANOPY GLAZING TYPE PLANS

ANGG XAL 1/2" = 1"

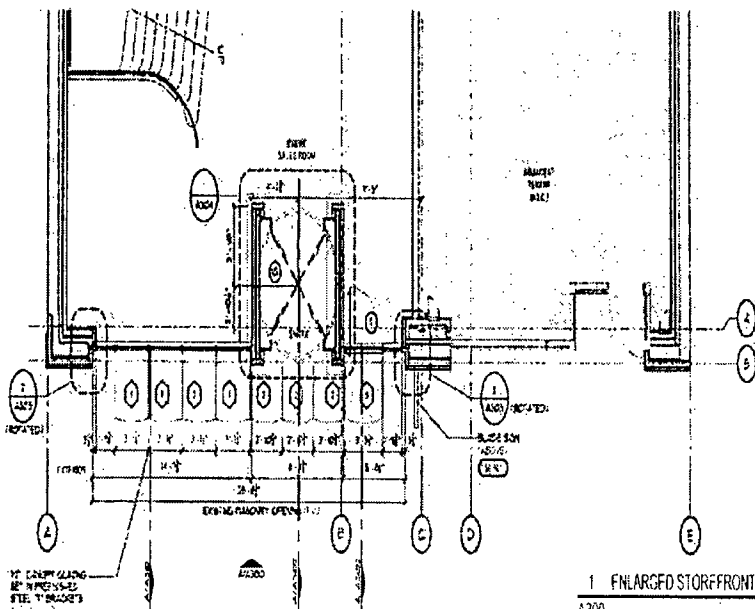

1 ENLARGED STOREFRONT PLAN

A300 SCALE 1/4" = 1"

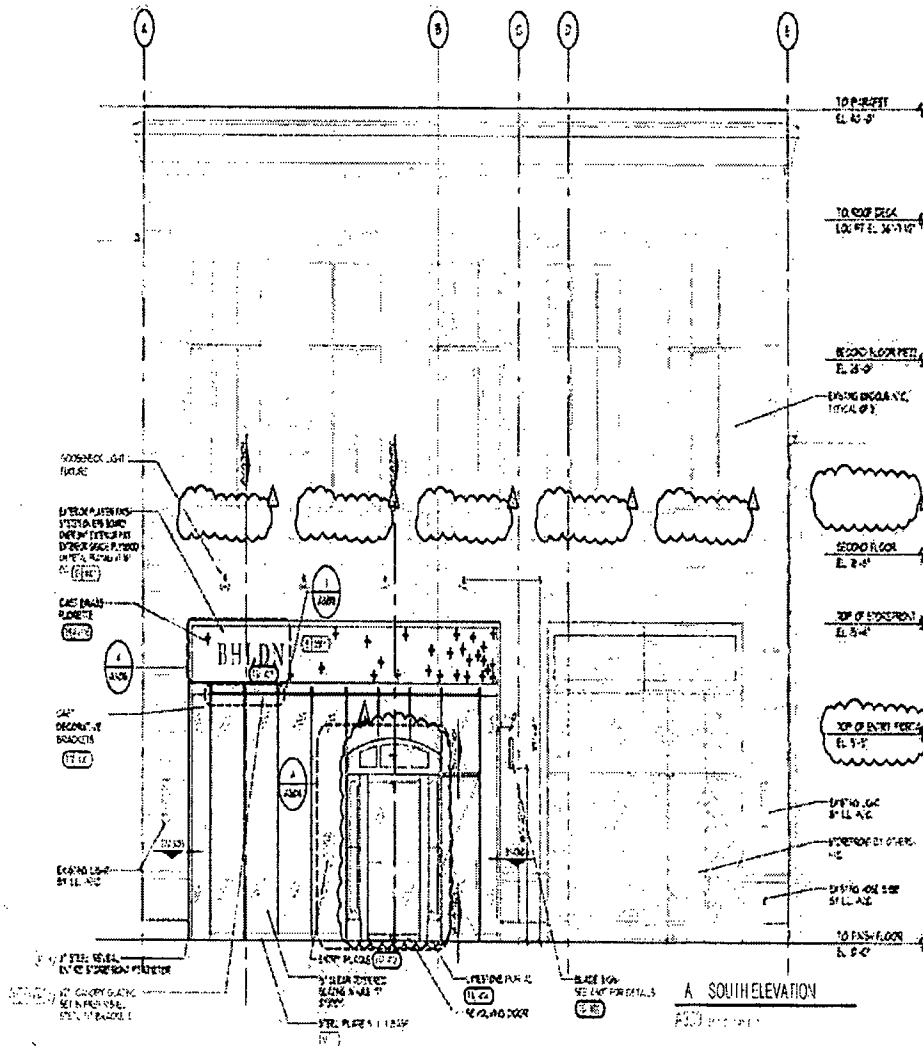

A SOUTH ELEVATION

A300 SCALE 1/4" = 1"

ARCHITECT OF RECORD

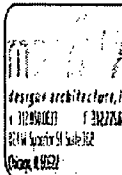

CONSTRUCTION ADMINISTRATION



ARCHITECT OF RECORD

CONSTRUCTION ADMINISTRATION

**BHLDN**

OWNER

DATE

CONSULTANT

DRAWN BY

NO.

ISSUE DATE

DATE

REVISION

DATE

REVISION

DATE

REVISION

DATE

REVISION

DATE

REVISION

DATE

REVISION

DATE

REVISION

DATE

SHEET TITLE

STOREFRONT - ENLARGED PLAN / ELEVATION

SHEET NO.

A

**A300**



**Department of Business Affairs and Consumer Protection**  
Small Business Center - Public Way Use Unit  
City Hall - 121 N. LaSalle Street, Room 800, Chicago, IL 60602  
312-74-GOBIZ / 312-744-6249 • (312) 744-1944 (TTY)  
<http://www.cityofchicago.org/bacp>

11/17/2021

Alderman Brendan Reilly  
Ward # 42  
City of Chicago  
City Hall, Room 800  
121 N. LaSalle Street  
Chicago, IL 60602

Re: An ordinance to use and maintain a portion of the public right-of-way for **4 Light Fixture(s)** for **BHLDN**, adjacent to the premises known as **8 E WALTON ST.**

Dear Alderman **Brendan Reilly**:

The applicant referenced above has requested the use of the public right-of-way for **Light Fixture(s)**. An ordinance has been prepared by the Department of Business Affairs and Consumer Protection - Small Business Center - Public Way Use Unit for presentation to the City Council. Because this request was made for properties located in your ward, as approved by you as per the attached, I respectfully request that you introduce the attached ordinance at the next City Council meeting.

If you have any questions regarding this ordinance, please contact Anthony Bertuca at (312) 744-5506.

**Department of Business Affairs and Consumer Protection**