



City of Chicago



O2017-2724

Office of the City Clerk

Document Tracking Sheet

Meeting Date:	3/29/2017
Sponsor(s):	Reilly (42)
Type:	Ordinance
Title:	Grant(s) of privilege in public way for Club Quarters
Committee(s) Assignment:	Committee on Transportation and Public Way

ORDINANCE
CLUB QUARTERS
Acct. No. 230085 - 1
Permit No. 1126073

Be It Ordained by the City Council of the City of Chicago:

SECTION 1. Permission and authority are hereby given and granted to CLUB QUARTERS, upon the terms and subject to the conditions of this ordinance to maintain and use, as now constructed, two (2) Flag Pole(s) projecting over the public right-of-way adjacent to its premises known as 75 E. Wacker Dr..

Said Flag Pole(s) at Wacker Drive measure(s):

Two (2) at twelve (12) feet in length, and one (1) foot in width for a total of twenty-four (24) square feet.

The location of said privilege shall be as shown on prints kept on file with the Department of Business Affairs and Consumer Protection and the Office of the City Clerk.

Said privilege shall be constructed in accordance with plans and specifications approved by the Department of Transportation (Division of Project Development).

This grant of privilege in the public way shall be subject to the provisions of Section 10-28-015 and all other required provisions of the Municipal Code of Chicago.

The grantee shall pay to the City of Chicago as compensation for the privilege #1126073 herein granted the sum of one hundred fifty (\$150.00) per annum in advance.

A 25% penalty will be added for payments received after due date.

The permit holder agrees to hold the City of Chicago harmless for any damage, relocation or replacement costs associated with damage, relocation or removal of private property caused by the City performing work in the public way.

Authority herein given and granted for a period of five (5) years from and after 02/27/2017.

Alderman _____

Brendan Reilly 42nd Ward

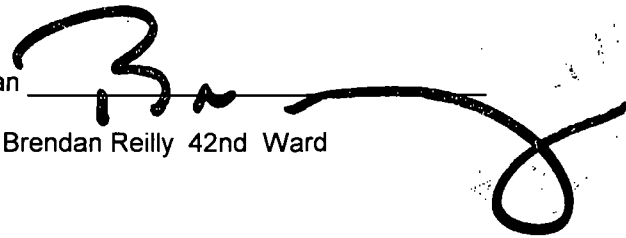
A large, stylized handwritten signature in black ink, appearing to read 'B. Reilly', is written over a horizontal line. The signature is fluid and cursive, with a large loop at the end.

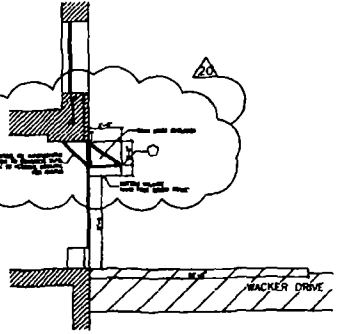
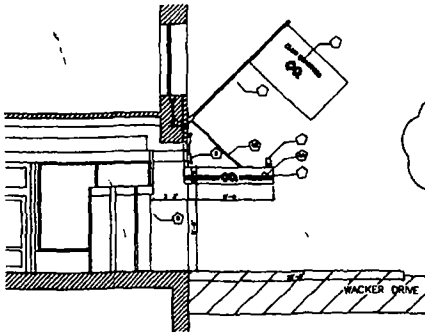
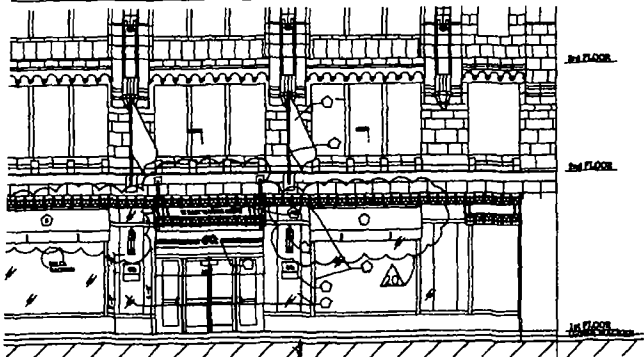

SECTION @ CO AWNING

SECTION @ TENANT AWNING

KEYED NOTES

1. FLAGPOLES PROVIDE (2) NEW 12'-0" PAINTED ALUMINUM FLAG POLE TO FIT INTO EXISTING BUILDING BRACKET
2. NYLON FLAG SIZE 5'-0" X 8'-0" OO BLUE WITH GOLD LETTERING AND LOGO (LETTERING 8" TALL, LOGO APPROX. 18" X 23")
3. 1/2" FLAG SIZE 5'-0" X 8'-0"
4. NEW SUNBRELLA FLAME-RETARDANT CANOAS AWNING ON GALVANIZED STEEL FRAME NAVY BLUE WITH GOLD ACCENT AND LOGO (LOGO 8 1/2" TALL) WITH MATCHING CANOAS UNDERSIDE COLOR ON TENANT AWNINGS TO BE DETERMINED
- 4A. 2 SPOTLIGHTS FOR FLAG LOCATED WITHIN CENTRAL AWNING
- 4B. BRASS TENSION ROD ATTACHED TO EXISTING SPANDREL BEAM ABOVE
5. NEW SUNBRELLA FLAME-RETARDANT CANOAS AWNINGS ON GALVANIZED STEEL ATTACHED TO EXISTING STOREFRONT (REINFORCE STOREFRONT MULLION)
6. NEW TART CALL LIGHT
7. CUSTOM BRASS LIGHT FIXTURES 18" TO BE ATTACHED TO COLUMN THROUGH GLASS
8. EXISTING BRASS ORNAMENT AND STOREFRONT TO REMAIN
9. LOCATION FOR NEW 18" X 18" BRASS PLAQUES EACH SIDE TO BE ATTACHED TO GLASS
10. NEW CLASS LITE TO BE PRE-DRILLED FOR LIGHT SOURCE SUPPORT

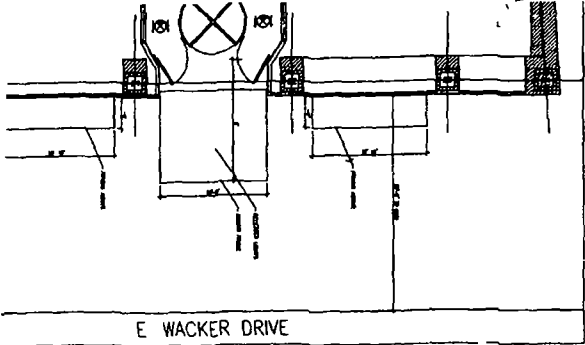

E WACKER DRIVE

WACKER FACADE WITH AWINGS

75 EAST WACKER DRIVE

CLARK QUINN
75 EAST WACKER DRIVE

CLARK QUINN DEVELOPMENT
ASSOCIATES
ARCHITECTS