



City of Chicago



O2017-8879

Office of the City Clerk

Document Tracking Sheet

Meeting Date:	12/13/2017
Sponsor(s):	Pawar (47)
Type:	Ordinance
Title:	Grant(s) of privilege in public way for Homesoul
Committee(s) Assignment:	Committee on Transportation and Public Way

ORDINANCE
Homesoul
Acct No 374632 - 1
Permit No 1130449

Be It Ordained by the City Council of the City of Chicago:

SECTION 1. Permission and authority are hereby given and granted to Homesoul, upon the terms and subject to the conditions of this ordinance to construct, install, maintain and use two (2) Light Fixture(s) projecting over the public right-of-way adjacent to its premises known as 4526 N. Lincoln Ave..

Said Light Fixture(s) at N Lincoln Ave measure(s):

Two (2) at one (1) foot in length, one (1) foot in width and nine (9) feet above grade level.

The location of said privilege shall be as shown on prints kept on file with the Department of Business Affairs and Consumer Protection and the Office of the City Clerk.

Said privilege shall be constructed in accordance with plans and specifications approved by the Department of Transportation (Division of Project Development).

This grant of privilege in the public way shall be subject to the provisions of Section 10-28-015 and all other required provisions of the Municipal Code of Chicago.

The grantee shall pay to the City of Chicago as compensation for the privilege #1130449 herein granted the sum of eighty (\$80 00) per annum in advance.

A 25% penalty will be added for payments received after due date.

The permit holder agrees to hold the City of Chicago harmless for any damage, relocation or replacement costs associated with damage, relocation or removal of private property caused by the City performing work in the public way

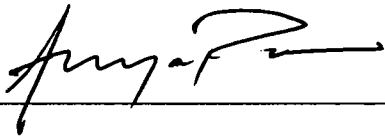

Authority herein given and granted for a period of five (5) years from and after Date of Passage.

Alderman 
Ameya Pawar 47th Ward

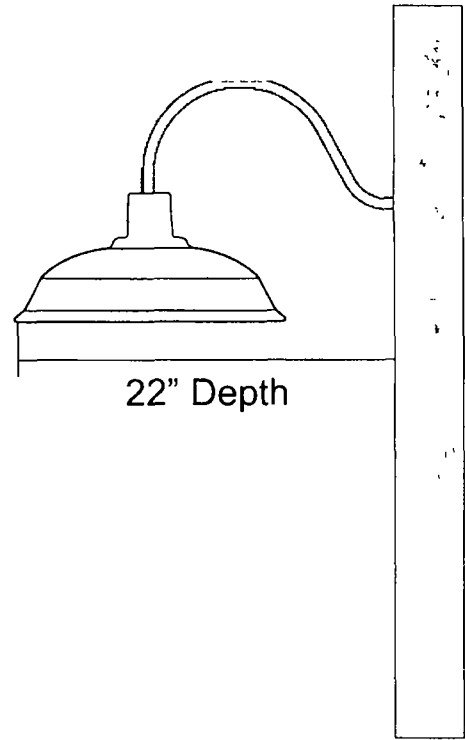
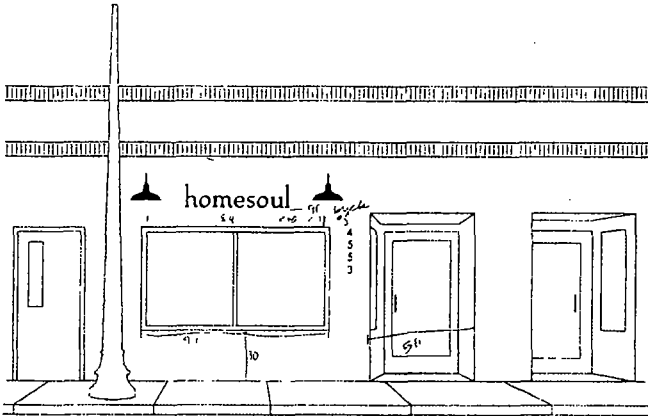
Homesoul



Scope of work
Install 2 exterior lights on building facade

 5500 N Kedzie Ave Chicago IL 60625 773 267-6007 sales@tfasigns.com	Client Name Homesoul	Start Date 03/27/2017	<ul style="list-style-type: none">• Client Approval• Landlord Approval	Sales Rep Seung Park
	Location 4526 N Lincoln Ave Chicago IL 60625	Last Revision 00/00/0000		Job# 00000
		Drawing# 00000a v1 s1 / e1		
		Page 2 of 2		



12/13/2017

Alderman **Ameya Pawar**
Ward # 47
City of Chicago
City Hall, Room 200
121 North LaSalle Street
Chicago, Illinois 60602

Re: An ordinance to use and maintain a portion of the public right-of-way for **two (2) light fixture(s)** for **Homesoul**, adjacent to the premises known as **4526 N. Lincoln Ave.**.

Dear Alderman **Ameya Pawar**:

The applicant referenced above has requested the use of the public right-of-way for a **light fixture(s)**. An ordinance has been prepared by the Department of Business Affairs and Consumer Protection – Small Business Center - Public Way Use Unit for presentation to the City Council. Because this request was made for properties located in your ward, as approved by you as per the attached, I respectfully request that you introduce the attached ordinance at the next City Council meeting.

If you have any questions regarding this ordinance, please contact Anthony Bertuca at (312) 744-5506.

Department of Business Affairs and Consumer Protection