



City of Chicago



O2016-4973

Office of the City Clerk Document Tracking Sheet

Meeting Date:	6/22/2016
Sponsor(s):	Solis (25)
Type:	Ordinance
Title:	Canopy(s) for 1035 W Van Buren Partners LLC
Committee(s) Assignment:	Committee on Transportation and Public Way

ORDINANCE
1035 W VAN BUREN PARTNERS LLC
Acct. No. 400190 - 2
Permit No. 1123548

Be It Ordained by the City Council of the City of Chicago:

SECTION 1. Permission and authority are hereby given and granted to 1035 W VAN BUREN PARTNERS LLC, upon the terms and subject to the conditions of this ordinance to construct, install, maintain and use one (1) Canopy(s) projecting over the public right-of-way adjacent to its premises known as 1035 W. Van Buren St..

Said Canopy(s) at W. Van Buren Street measure(s):

One (1) at fifty-one point five (51.5) feet in length, and ten (10) feet in width for a total of five hundred fifteen (515) square feet.

The location of said privilege shall be as shown on prints kept on file with the Department of Business Affairs and Consumer Protection and the Office of the City Clerk.

Said privilege shall be constructed in accordance with plans and specifications approved by the Zoning Department - Signs.

This grant of privilege in the public way shall be subject to the provisions of Section 10-28-015 and all other required provisions of the Municipal Code of Chicago.

The grantee shall pay to the City of Chicago as compensation for the privilege #1123548 herein granted the sum of seventy-six dollars and fifty cents (\$76.50) per annum in advance.

A 25% penalty will be added for payments received after due date.

The permit holder agrees to hold the City of Chicago harmless for any damage, relocation or replacement costs associated with damage, relocation or removal of private property caused by the City performing work in the public way.

Authority herein given and granted for a period of five (5) years from and after Date of Passage.

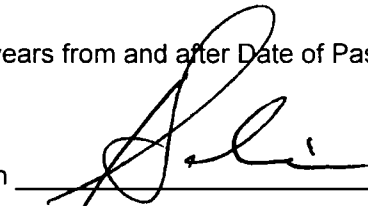
Alderman  _____
Daniel S. Solis 25th Ward

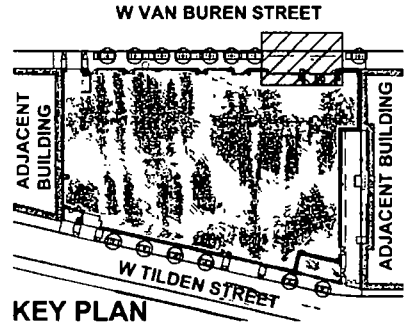
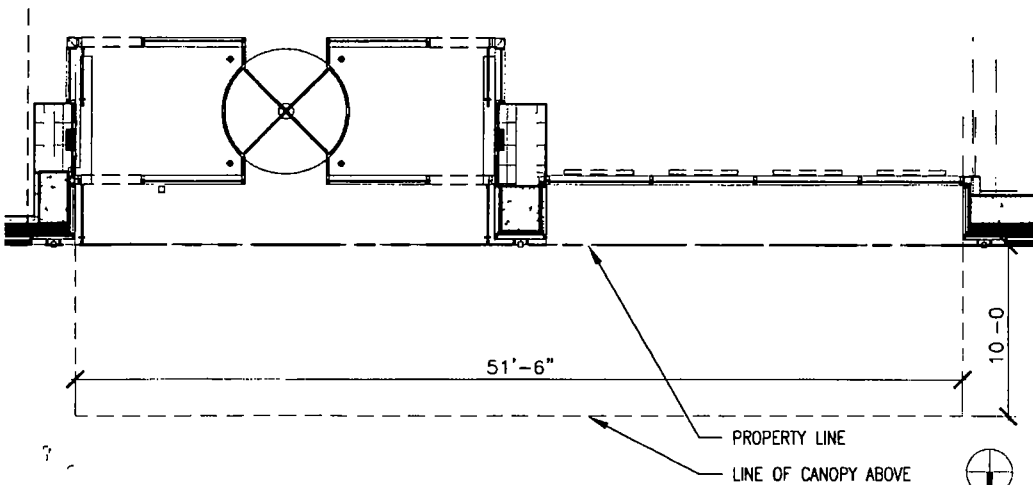
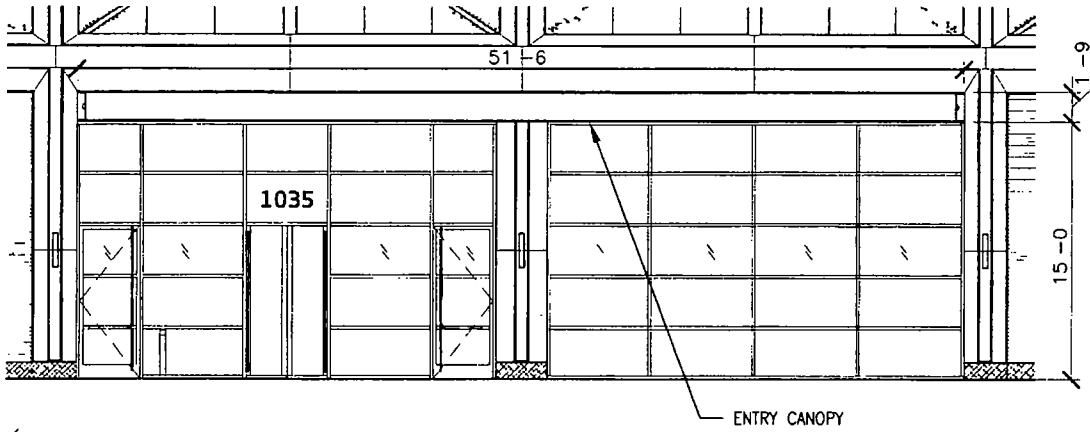

GOP-SK. ENTRY CANOPY - W VAN BUREN STREET
SCALE 1/4" = 1'-0"

1035 W VAN BUREN

06 MAY 2016

Applicant 1035 WEST VAN BUREN PARTNERS LLC
Address 1035 W Van Buren Chicago IL

Morris Admi Architects
www.ma.com



GIR|E|C ARCHITECTS



Department of Business Affairs and Consumer Protection
Small Business Center - Public Way Use Unit
City Hall - 121 N. LaSalle Street, Room 800 • Chicago, IL 60602
312-74-GOBIZ / 312-744-6249 • (312) 744-1944 (TTY)
<http://www.cityofchicago.org/bacp>

06/22/2016

Alderman **Daniel S. Solis**
Ward # **25**
City of Chicago
City Hall, Room **304**
121 North LaSalle Street
Chicago, Illinois 60602

Re: An ordinance to use and maintain a portion of the public right-of-way for **one (1) canopy(ies)** for **1035 W VAN BUREN PARTNERS LLC**, adjacent to the premises known as **1035 W. Van Buren St.**

Dear Alderman **Daniel S. Solis**:

The applicant referenced above has requested the use of the public right-of-way for a **canopy(ies)**. An ordinance has been prepared by the Department of Business Affairs and Consumer Protection – Small Business Center - Public Way Use Unit for presentation to the City Council. Because this request was made for properties located in your ward, as approved by you as per the attached, I respectfully request that you introduce the attached ordinance at the next City Council meeting.

If you have any questions regarding this ordinance, please contact Anthony Bertuca at (312) 744-5506.

Department of Business Affairs and Consumer Protection