



City of Chicago



O2016-304

Office of the City Clerk

Document Tracking Sheet

Meeting Date:	1/13/2016
Sponsor(s):	Tunney (44)
Type:	Ordinance
Title:	Grant(s) of privilege in public way for M&R Development LLC - bollards
Committee(s) Assignment:	Committee on Transportation and Public Way

ORDINANCE
M & R DEVELOPMENT, LLC
Acct. No. 335655 - 4
Permit No. 1121144

Be It Ordained by the City Council of the City of Chicago:

SECTION 1. Permission and authority are hereby given and granted to M & R DEVELOPMENT, LLC, upon the terms and subject to the conditions of this ordinance to construct, install, maintain and use six (6) Bollard(s) on the public right-of-way adjacent to its premises known as 1025 W. Addison St..

Said Bollard(s) at N. Sheffield Avenue measure(s):

Two (2) at one (1) foot in length, and one (1) foot in width for a total of two (2) square feet.

Said Bollard(s) at Public Alley measure(s):

Four (4) at one (1) foot in length, and one (1) foot in width for a total of four (4) square feet.

The location of said privilege shall be as shown on prints kept on file with the Department of Business Affairs and Consumer Protection and the Office of the City Clerk.

Said privilege shall be constructed in accordance with plans and specifications approved by the Department of Planning and Development and Department of Transportation (Division of Project Development).

This grant of privilege in the public way shall be subject to the provisions of Section 10-28-015 and all other required provisions of the Municipal Code of Chicago.

The grantee shall pay to the City of Chicago as compensation for the privilege #1121144 herein granted the sum of four hundred fifty (\$450.00) per annum in advance.

A 25% penalty will be added for payments received after due date.

The permit holder agrees to hold the City of Chicago harmless for any damage, relocation or replacement costs associated with damage, relocation or removal of private property caused by the City performing work in the public way.

Authority herein given and granted for a period of five (5) years from and after Date of Passage.

Alderman

Thomas Tunney 44th Ward

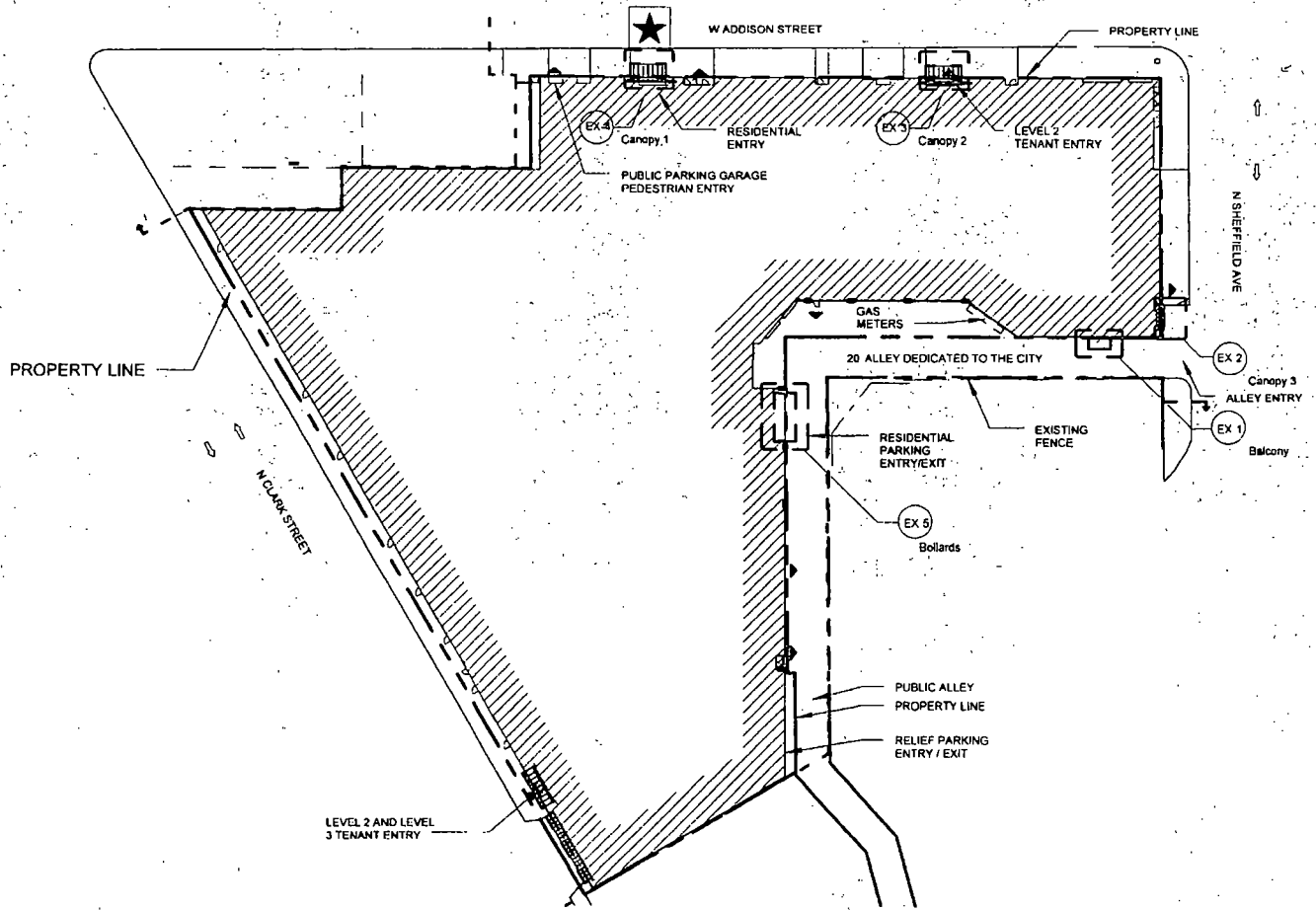

© 2015 Solomon Cordwell Buenz

DRAWING TITLE Site Plan

DATE 12 30 2015

PROJECT NAME ADDISON PARK ON CLARK

PROJECT # 2014034

EX-0

Architecture Planning Interior Design 625 N Michigan Ave Chicago IL 60611 T 312 896 1100 F 312 896 1200

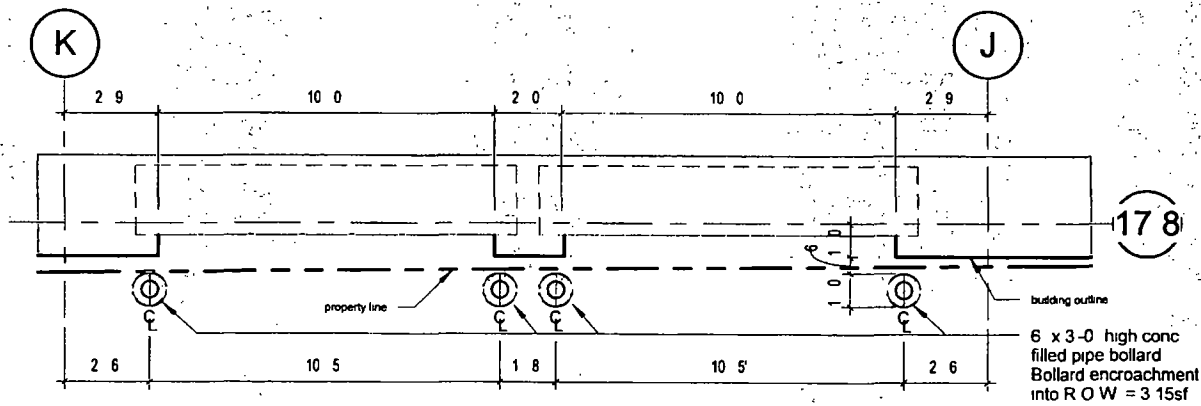

© 2015 Solomon Cordwell Buenz

DRAWING TITLE Sheffield Alley Residential Entry Bollards DATE 12 30 2015

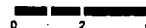

PROJECT NAME ADDISON PARK ON CLARK PROJECT # 2014034



EX-5

Architecture Planning Interior Design 625 N Michigan Ave Chicago IL 60611 T 312 896 1100 F 312 896 1200

