



City of Chicago



O2017-4008

Office of the City Clerk

Document Tracking Sheet

Meeting Date:	5/24/2017
Sponsor(s):	Moreno (1)
Type:	Ordinance
Title:	Awning(s) for FT Wicker Park
Committee(s) Assignment:	Committee on Transportation and Public Way

ORDINANCE
FT WICKER PARK
Acct. No. 404390 - 1
Permit No. 1128155

Be It Ordained by the City Council of the City of Chicago:

SECTION 1. Permission and authority are hereby given and granted to FT WICKER PARK, upon the terms and subject to the conditions of this ordinance to maintain and use, as now constructed, four (4) Awning(s) projecting over the public right-of-way adjacent to its premises known as 1570 1/2 N. Damen Ave..

Said Awning(s) at N. Damen Avenue measure(s):

One (1) at seven (7) feet in length, and three point five (3.5) feet in width for a total of twenty-four point five (24.5) square feet.

One (1) at nine (9) feet in length, and three (3) feet in width for a total of twenty-seven (27) square feet.

One (1) at six (6) feet in length, and three (3) feet in width for a total of eighteen (18) square feet.

One (1) at nine (9) feet in length, and three (3) feet in width for a total of twenty-seven (27) square feet.

The location of said privilege shall be as shown on prints kept on file with the Department of Business Affairs and Consumer Protection and the Office of the City Clerk.

Said privilege shall be constructed in accordance with plans and specifications approved by the Zoning Department - Signs.

This grant of privilege in the public way shall be subject to the provisions of Section 10-28-015 and all other required provisions of the Municipal Code of Chicago.

The grantee shall pay to the City of Chicago as compensation for the privilege #1128155 herein granted the sum of one hundred seventy-five (\$175.00) per annum in advance.

A 25% penalty will be added for payments received after due date.

The permit holder agrees to hold the City of Chicago harmless for any damage, relocation or replacement costs associated with damage, relocation or removal of private property caused by the City performing work in the public way.

Authority herein given and granted for a period of five (5) years from and after Date of Passage.

Alderman _____

Proco Joe Moreno 1st Ward

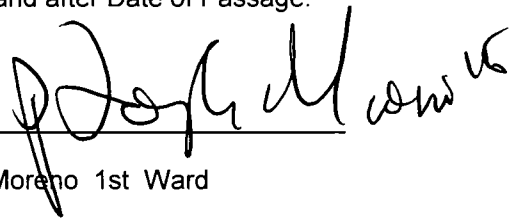
A handwritten signature in black ink, appearing to read "Joe Moreno", is written over a horizontal line. To the right of the signature, there are some additional handwritten marks that look like "10/15/16".

20'-0"

36"
18"

FLASH TACO

INDIVIDUAL NEON SILHOUETTE ILLUMINATED LETTER DISPLAY 1/2" = 1'-0"

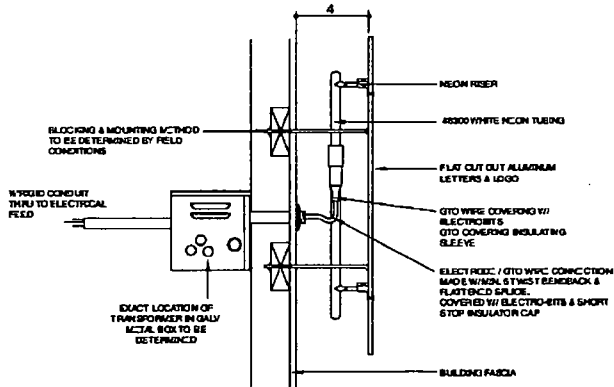

SECTION THRU DETAIL



OLYMPIC SIGNS

account representative: R WHITEHEAD / client: **FLASH TACO** / drawn by: JOHN W / job#: 17-6808 / 3-17-17 / rev #

1130 N. Garfield / Lombard, IL 60148 / Ph: 630.424.6100 / Fax: 630.424.6120 / WWW.OLYSIGNS.COM

THIS IS AN ORIGINAL UNPUBLISHED DRAWING SUBMITTED BY CLIENT FOR INFO AND PLANNING PURPOSES ONLY. THIS IS NOT TO BE CONSIDERED A CONTRACT. CONSULT WITH ARCHITECT FOR ALL PROJECT REQUIREMENTS. ANY CHANGES TO THIS DRAWING MUST BE APPROVED BY ARCHITECT AND CLIENT. THIS DRAWING IS THE PROPERTY OF OLYMPIC SIGNS, INC. AND IS NOT TO BE REPRODUCED OR TRANSMITTED IN ANY FORM OR BY ANY MEANS, ELECTRONIC OR MECHANICAL, INCLUDING PHOTOCOPYING, RECORDING, OR BY ANY INFORMATION STORAGE AND RETRIEVAL SYSTEM. WITHOUT THE WRITTEN PERMISSION OF OLYMPIC SIGNS, INC. ANY USE OF THIS DRAWING IS AT THE USER'S SOLE RISK AND WITHOUT LIABILITY TO OLYMPIC SIGNS, INC.

page 1 of 1

Customer's Signature _____ Date _____

Comments:

EXISTING

PROPOSED



05/24/2017

Alderman Proco Joe Moreno
Ward # 01
City of Chicago
City Hall, Room 300
121 North LaSalle Street
Chicago, Illinois 60602

Re: An ordinance to use and maintain a portion of the public right-of-way for **four (4) awning(s)** for **FT WICKER PARK**, adjacent to the premises known as **1570 1/2 N. Damen Ave.**.

Dear Alderman **Proco Joe Moreno**:

The applicant referenced above has requested the use of the public right-of-way for a **awning(s)**. An ordinance has been prepared by the Department of Business Affairs and Consumer Protection – Small Business Center - Public Way Use Unit for presentation to the City Council. Because this request was made for properties located in your ward, as approved by you as per the attached, I respectfully request that you introduce the attached ordinance at the next City Council meeting.

If you have any questions regarding this ordinance, please contact Anthony Bertuca at (312) 744-5506.

Department of Business Affairs and Consumer Protection