



Office of the Chicago City
Clerk



O2012-4777

Office of the City Clerk

City Council Document Tracking Sheet

Meeting Date:	6/27/2012
Sponsor(s):	Osterman, Harry (48)
Type:	Ordinance
Title:	Grant(s) of privilege in public way for Chicago Northside Toyota
Committee(s) Assignment:	Committee on Transportation and Public Way

ORDINANCE
CHICAGO NORTHSIDE TOYOTA
Acct. No. 290398 - 1
Permit No. 1097984

Be It Ordained by the City Council of the City of Chicago:

SECTION 1. Permission and authority are hereby given and granted to CHICAGO NORTHSIDE TOYOTA, upon the terms and subject to the conditions of this ordinance to maintain and use four (4) sign(s) projecting over the public right-of-way attached to its premises known as 5625 N. Broadway .

Said sign structure(s) measures as follows; along N Broadway:

One (1) at seventeen (17) feet in length, six point five (6.5) feet in height and thirty-four (34) feet above grade level.

One (1) at fourteen point four two (14.42) feet in length, four (4) feet in height and fifteen point six seven (15.67) feet above grade level.

One (1) at eighteen (18) feet in length, three (3) feet in height and fifteen point six seven (15.67) feet above grade level.

One (1) at twelve (12) feet in length, two (2) feet in height and fifteen point six seven (15.67) feet above grade level.

The location of said privilege shall be as shown on prints kept on file with the Department of Business Affairs and Consumer Protection and the Office of the City Clerk.

Said privilege shall be constructed in accordance with plans and specifications approved by the Department of Transportation (Division of Project Development) and Zoning Department - Signs.

This grant of privilege in the public way shall be subject to the provisions of Section 10-28-015 and all other required provisions of the Municipal Code of Chicago.

The grantee shall pay to the City of Chicago as compensation for the privilege #1097984 herein granted the sum of one thousand (\$1,000.00) per annum in advance.

A 25% penalty will be added for payments received after due date.

The permit holder agrees to hold the City of Chicago harmless for any damage, relocation or replacement costs associated with damage, relocation or removal of private property caused by the City performing work in the public way.

Authority herein given and granted for a period of five (5) years from and after Date of Passage.

Alderman



Harry Osterman 48th Ward

5

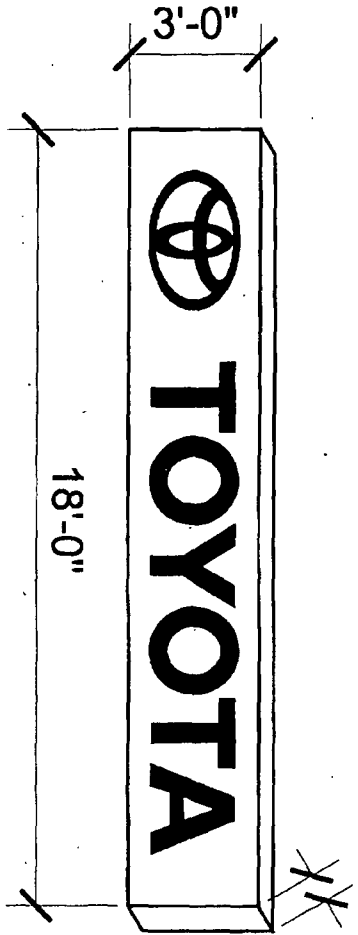
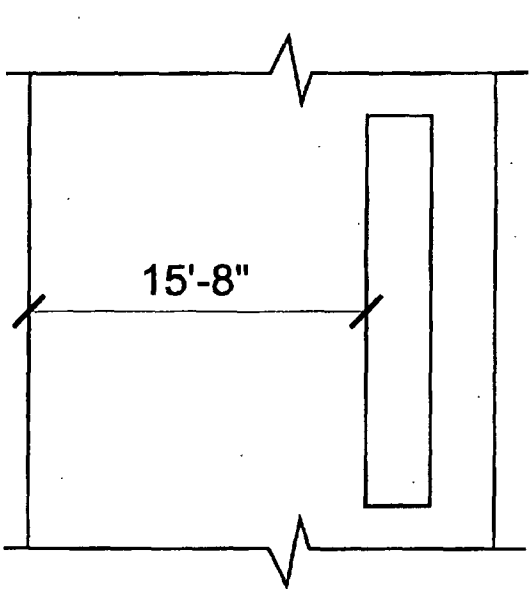

100281416

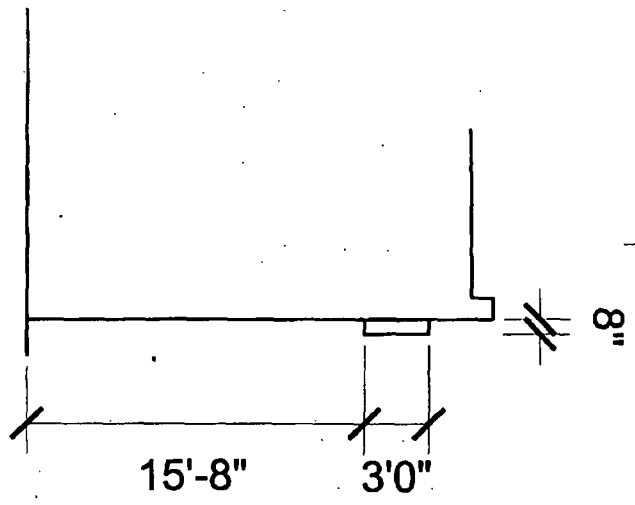

NORTHSIDE TOYOTA
 5625 N BROADWAY
 CHICAGO, IL

DATE: 1/12/2011
 DESIGN: SYNERGIES, LTD.
 11000 LACONIA RD
 CHICAGO, IL 60642
 PROJECT: FRONT SIGN
 1.0



2nd ATTEMPT AT INTRODUCTION

06/27/2012

Alderman **Harry Osterman**
Ward # 48
City of Chicago
City Hall, Room 300
121 North LaSalle Street
Chicago, Illinois 60602

Re: An ordinance to use and maintain a portion of the public right-of-way for **four (4) sign(s)** for
CHICAGO NORTHSIDE TOYOTA, adjacent to the premises known as **5625 N. Broadway**.

Dear Alderman **Harry Osterman**:

The applicant referenced above has requested the use of the public right-of-way for a **sign(s)**. An ordinance has been prepared by the Department of Business Affairs and Consumer Protection – Business Assistance Center - Public Way Use Unit for presentation to the City Council. Because this request was made for properties located in your ward, as approved by you as per the attached, I respectfully request that you introduce the attached ordinance at the next City Council meeting.

If you have any questions regarding this ordinance, please contact Anthony Bertuca at (312) 744-5506.

Department of Business Affairs and Consumer Protection