



City of Chicago



O2015-5954

Office of the City Clerk

Document Tracking Sheet

Meeting Date:	7/29/2015
Sponsor(s):	Cappleman (46)
Type:	Ordinance
Title:	Grant(s) of privilege in public way for 3800 North Lake Shore Drive - light fixture
Committee(s) Assignment:	Committee on Transportation and Public Way

ORDINANCE
3800 NORTH LAKE SHORE DRIVE
Acct. No. 5868 - 1
Permit No. 1119668

Be It Ordained by the City Council of the City of Chicago:

SECTION 1. Permission and authority are hereby given and granted to 3800 NORTH LAKE SHORE DRIVE, upon the terms and subject to the conditions of this ordinance to maintain and use, as now constructed, one (1) Light Fixture(s) projecting over the public right-of-way adjacent to its premises known as 3800 N. Lake Shore Dr..

Said Light Fixture(s) at N. Lake Shore Drive measure(s):
One (1) at one (1) foot in length, one (1) foot in width and ten (10) feet above grade level.

The location of said privilege shall be as shown on prints kept on file with the Department of Business Affairs and Consumer Protection and the Office of the City Clerk.

Said privilege shall be constructed in accordance with plans and specifications approved by the Department of Transportation (Division of Project Development).

This grant of privilege in the public way shall be subject to the provisions of Section 10-28-015 and all other required provisions of the Municipal Code of Chicago.

The grantee shall pay to the City of Chicago as compensation for the privilege #1119668 herein granted the sum of seventy-five (\$75.00) per annum in advance.

A 25% penalty will be added for payments received after due date.

The permit holder agrees to hold the City of Chicago harmless for any damage, relocation or replacement costs associated with damage, relocation or removal of private property caused by the City performing work in the public way.

Authority herein given and granted for a period of five (5) years from and after 07/28/2015.

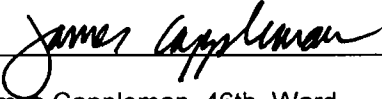
Alderman 
James Cappleman 46th Ward

1950-1951
1952-1953
1954-1955
1956-1957
1958-1959
1960-1961
1962-1963
1964-1965
1966-1967
1968-1969
1970-1971
1972-1973
1974-1975
1976-1977
1978-1979
1980-1981
1982-1983
1984-1985
1986-1987
1988-1989
1990-1991
1992-1993
1994-1995
1996-1997
1998-1999
2000-2001
2002-2003
2004-2005
2006-2007
2008-2009
2010-2011
2012-2013
2014-2015
2016-2017
2018-2019
2020-2021
2022-2023
2024-2025

Account # - Site # : 5868 - 1
Legal Name: 3800 N. Lake Shore Drive Condo Association
PWU Permit #: 1092467
PWU Type: Light Fixture
PWU Location: 3800 N. Lake Shore Drive

Agency Approvals

- UL 1638 Listed (AC only)
- cUL Listed (AC only)

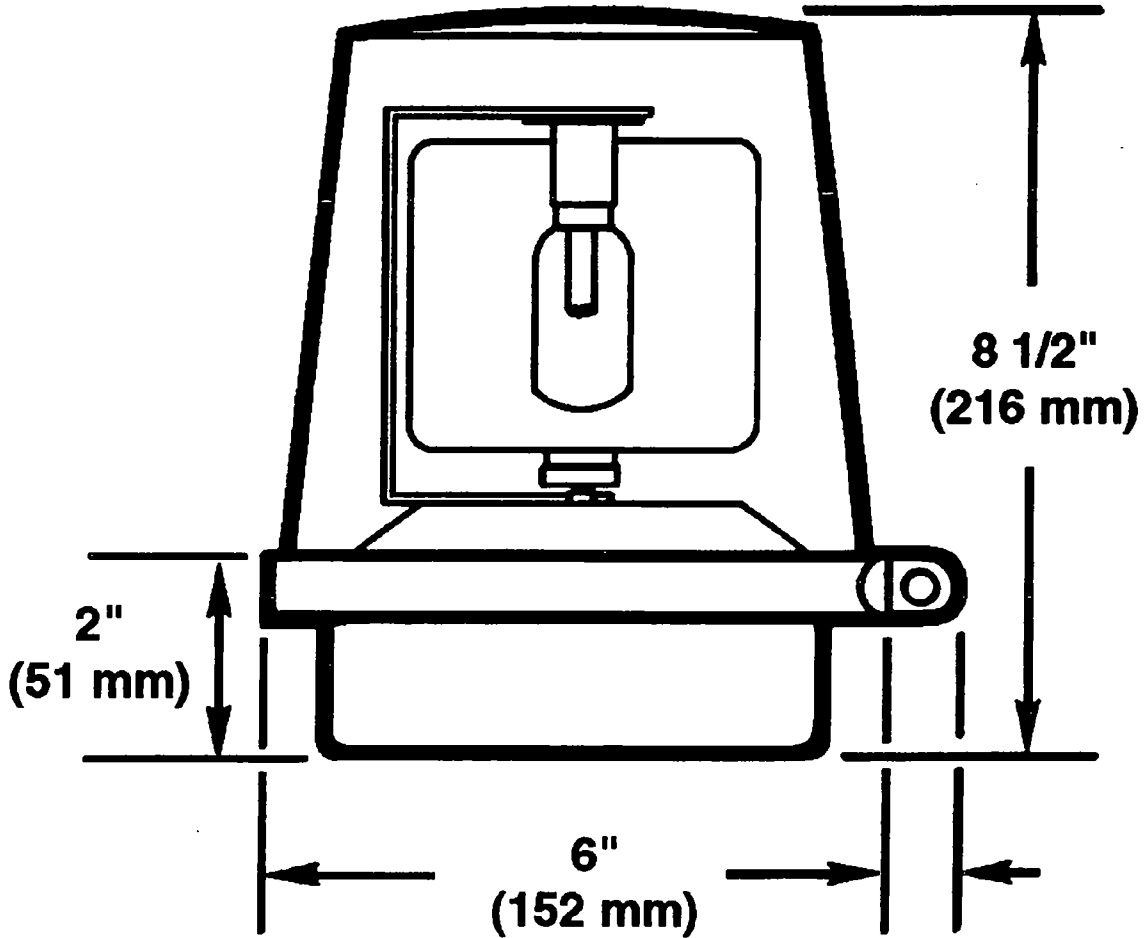
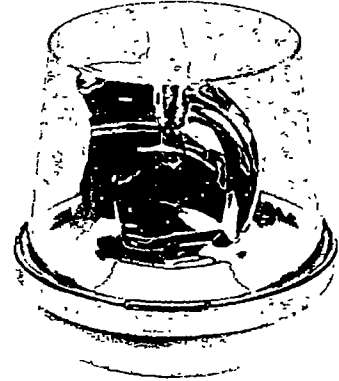



07/29/2015

Alderman **James Cappleman**
Ward # 46
City of Chicago
City Hall, Room 200
121 North LaSalle Street
Chicago, Illinois 60602

Re: An ordinance to use and maintain a portion of the public right-of-way for **one (1) light fixture(s)** for **3800 NORTH LAKE SHORE DRIVE**, adjacent to the premises known as **3800 N. Lake Shore Dr.**

Dear Alderman **James Cappleman**:

The applicant referenced above has requested the use of the public right-of-way for a **light fixture(s)**. An ordinance has been prepared by the Department of Business Affairs and Consumer Protection – Small Business Center - Public Way Use Unit for presentation to the City Council. Because this request was made for properties located in your ward, as approved by you as per the attached, I respectfully request that you introduce the attached ordinance at the next City Council meeting.

If you have any questions regarding this ordinance, please contact Anthony Bertuca at (312) 744-5506.

Department of Business Affairs and Consumer Protection