



# City of Chicago



O2015-5110

Office of the City Clerk

## Document Tracking Sheet

<b>Meeting Date:</b>	6/17/2015
<b>Sponsor(s):</b>	Solis (25)
<b>Type:</b>	Ordinance
<b>Title:</b>	Grant(s) of privilege in public way for Fairlife
<b>Committee(s) Assignment:</b>	Committee on Transportation and Public Way

ORDINANCE  
FAIRLIFE  
Acct. No. 384721 - 1  
Permit No. 1109119

*Be It Ordained by the City Council of the City of Chicago:*

SECTION 1. Permission and authority are hereby given and granted to FAIRLIFE, upon the terms and subject to the conditions of this ordinance to maintain and use two (2) sign(s) projecting over the public right-of-way attached to its premises known as 1001 W. Adams St.:

Said sign structure(s) measures as follows; along W ADAMS ST:

One (1) at nine point five (9.5) feet in length, four point four two (4.42) feet in height and eleven (11) feet above grade level.

Said sign structure(s) measures as follows; along MORGAN:

One (1) at nine point five (9.5) feet in length, four point four two (4.42) feet in height and eleven (11) feet above grade level.

The location of said privilege shall be as shown on prints kept on file with the Department of Business Affairs and Consumer Protection and the Office of the City Clerk.

Said privilege shall be constructed in accordance with plans and specifications approved by the Department of Transportation (Division of Project Development) and Zoning Department - Signs.

This grant of privilege in the public way shall be subject to the provisions of Section 10-28-015 and all other required provisions of the Municipal Code of Chicago.

The grantee shall pay to the City of Chicago as compensation for the privilege #1109119 herein granted the sum of six hundred (\$600.00) per annum in advance.

A 25% penalty will be added for payments received after due date.

The permit holder agrees to hold the City of Chicago harmless for any damage, relocation or replacement costs associated with damage, relocation or removal of private property caused by the City performing work in the public way.

Authority herein given and granted for a period of five (5) years from and after Date of Passage.

Alderman,

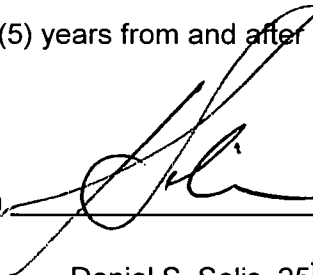

Daniel S. Solis 25<sup>th</sup> Ward

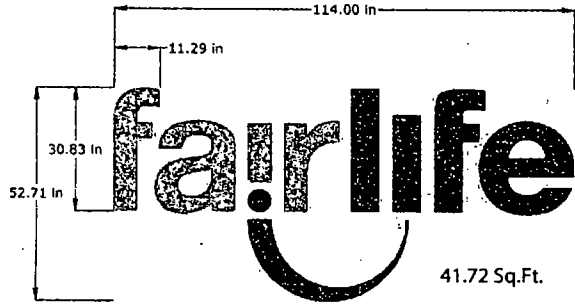

One set of individually mounted Channel Letters each elevation, internally illuminated with LEDs.

Acrylic faces with Pantones 285 & 376.

Returns and Trimcap to match pantone face colors

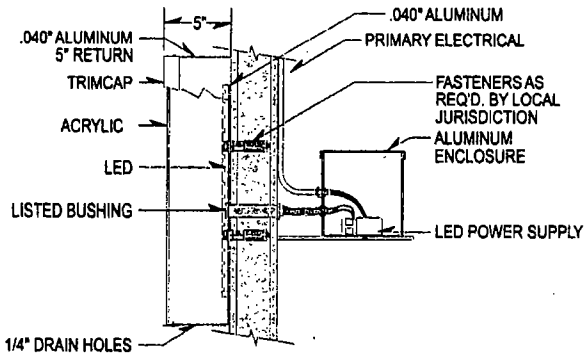

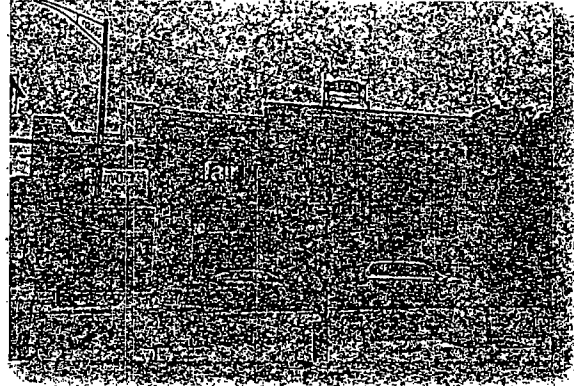

North elevation

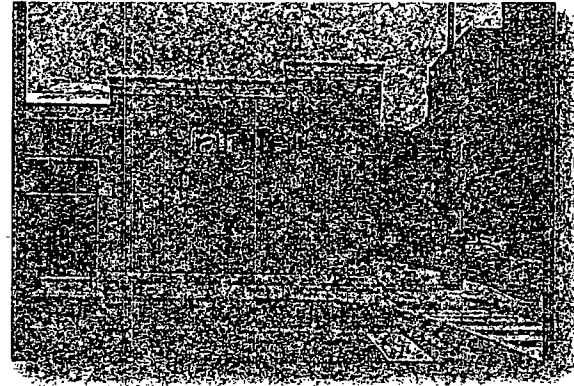

East elevation



**ATTENTION: PROOF ALL DRAWINGS CAREFULLY! IT IS THE RESPONSIBILITY OF THE CUSTOMER TO APPROVE COLOR, STYLE, SHAPE, PROPORTION OF GRAPHICS AND LOGOS, AND SPELLING OF TRADEMARKS AND SERVICEMARKS.**

 <p><b>Awning Sign &amp; Lighting Group, Inc.</b> 1405 Broadway Drive, Suite D   Addison, IL 60101 708.948.9700</p>	<p><b>We've got you covered!</b></p> <p>Design Fabrication Installation &amp; Service Painting Maintenance Project Management Permits Signage Sign Design Customized Signs Display Counter Displays Electronic Signs</p> <p>Platinum In-Store Centers Interior Signs A-11 Signs Decorative Signs Monument Signs Metal Signs Billboards Photo Signs Photo &amp; Video Signs Fluorescent Signs Plasma Signs Specialty Commercial Location Video Displays</p>	<p>Project/Location: <b>FairLife</b> 1001 West Adams Chicago, IL</p>	<p>ACCOUNT REP: <b>KENT WEBER</b> PROJECT MANAGER: <b>KENT STONEBURNER</b> DRAWN BY: <b>E. SADDLER</b></p> <p>ALL ELECTRICAL SIGNS ARE TO COMPLY WITH ILL. AND ARTICLE 600 OF THE N.E.C. STANDARDS, INCLUDING THE PROPER GROUNDING AND BONDING OF ALL SIGNS</p> <p>                  Underwriter's Laboratories                   ETEC                  ELECTRICAL TO ILL. WITH COMPONENTS APPROVED BY ETL AND ILL. STANDARDS.             </p>	<p>DATE: <b>09/21/2013</b></p> <p>SCALE: _____</p> <p>SHEET #: _____</p> <p>DESIGN ORDER #: _____</p> <p>FILE NAME: _____</p>	<p>REVISIONS: _____</p> <p>CLIENT APPROVAL DATE: _____</p> <p>LANDLORD APPROVAL DATE: _____</p>
	<p><small>This original drawing is provided as part of a planned project and is not to be exhibited, copied or reproduced without the written permission of Awning Sign &amp; Lighting Group, Inc or its authorized agent. © 2012</small></p>				



Department of Business Affairs and Consumer Protection  
Small Business Center - Public Way Use Unit  
City Hall - 121 N LaSalle Street, Room 800 • Chicago, IL 60602  
312-74-GOBIZ / 312-744-6249 • (312) 744-1944 (TTY)  
<http://www.cityofchicago.org/bacp>

**06/17/2015**

Alderman **Daniel S. Solis**  
Ward # **25**  
City of Chicago  
City Hall, Room **203**  
121 North LaSalle Street  
Chicago, Illinois 60602

Re: An ordinance to use and maintain a portion of the public right-of-way for **two (2) sign(s)** for **FAIRLIFE**, adjacent to the premises known as **1001 W. Adams St.**

Dear Alderman **Daniel S. Solis**:

The applicant referenced above has requested the use of the public right-of-way for a **sign(s)**. An ordinance has been prepared by the Department of Business Affairs and Consumer Protection – Small Business Center - Public Way Use Unit for presentation to the City Council. Because this request was made for properties located in your ward, as approved by you as per the attached, I respectfully request that you introduce the attached ordinance at the next City Council meeting.

If you have any questions regarding this ordinance, please contact Anthony Bertuca at (312) 744-5506.

**Department of Business Affairs and Consumer Protection**