



# City of Chicago



O2014-2089

Office of the City Clerk

## Document Tracking Sheet

<b>Meeting Date:</b>	3/5/2014
<b>Sponsor(s):</b>	Osterman (48)
<b>Type:</b>	Ordinance
<b>Title:</b>	Grant(s) of privilege in public way for North Shore Auto Service, Inc.
<b>Committee(s) Assignment:</b>	Committee on Transportation and Public Way

**ORDINANCE**

**NORTH SHORE AUTO SERVICE INC**  
Acct. No. 37644 - 1  
Permit No. 1109855

**ORDINANCE**

**NORTH SHORE AUTO SERVICE INC**  
Acct. No. 37644 - 1  
Permit No. 1109855

**ORDINANCE**  
**NORTH SHORE AUTO SERVICE INC**  
Acct. No. 37644 - 1  
Permit No. 1109855

*Be It Ordained by the City Council of the City of Chicago:*

**SECTION 1.** Permission and authority are hereby given and granted to **NORTH SHORE AUTO SERVICE INC**, upon the terms and subject to the conditions of this ordinance to maintain and use one (1) sign(s) projecting over the public right-of-way attached to its premises known as 6240 North Broadway.

Said sign structure(s) measures as follows; along Broadway:  
One (1) at forty-five (45) feet in length, two point three three (2.33) feet in height and twelve (12) feet above grade level.

The location of said privilege shall be as shown on prints kept on file with the Department of Business Affairs and Consumer Protection and the Office of the City Clerk.

Said privilege shall be constructed in accordance with plans and specifications approved by the Department of Transportation (Division of Project Development) and Zoning Department - Signs.

This grant of privilege in the public way shall be subject to the provisions of Section 10-28-015 and all other required provisions of the Municipal Code of Chicago.

The grantee shall pay to the City of Chicago as compensation for the privilege #1109855 herein granted the sum of three hundred (\$300.00) per annum in advance.

A 25% penalty will be added for payments received after due date.

The permit holder agrees to hold the City of Chicago harmless for any damage, relocation or replacement costs associated with damage, relocation or removal of private property caused by the City performing work in the public way.

Authority herein given and granted for a period of five (5) years from and after Date of Passage.

Alderman \_\_\_\_\_

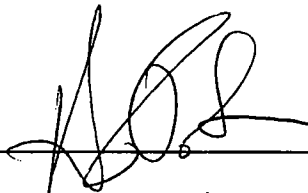

Harry Osterman 48<sup>th</sup> Ward

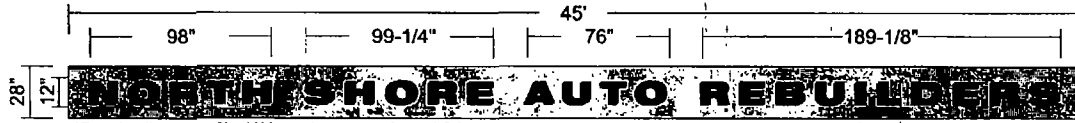

\*Panel splits every 8' - 10' based on natural word & letter gaps



Fabricated 1-1/2" Deep broke form channel pans with .063 aluminum backs with face mounted .090 aluminum face with counter sunk screws into pan face

Fabricated 3" Deep face lit channel letters with std black .040 aluminum coil returns and .063 backs, 3/16" #7328 white acrylic faces with std 1" black trimcap Applied 3M Black Perforated Film for day-black faces / night - white illumination

Entire unit mounted to wall with angle bracket anchored to wall with necessary anchors  
\*\*Survey required\*\*

Logo Face -  
3M Black  
Perforated Film

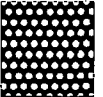

Backpanel  
MP Brushed  
Aluminum Silver

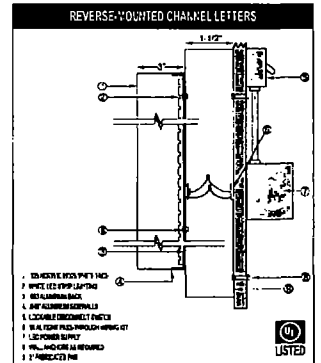

**SOUTH WATER**  
SIGNS

934 N Church  
Elmhurst, IL 60126

tel 630 333.4900  
fax 630 333.4915

CLIENT  
North Shore Auto Builders  
  
CUSTOMER APPROVAL

PROJECT NAME  
Exterior ID Signs  
6240 N Broadway, Chicago IL  
  
TRACKER NUMBER  
7005492

DATE  
10.04.13  
  
DRAWN BY  
PM

REV: 10.16.13  
10.29.13

THIS DRAWING IS THE PROPERTY  
OF SOUTH WATER SIGNS LLC  
ALL RIGHTS OF REPRODUCTION  
ARE RESERVED BY  
SOUTH WATER SIGNS LLC  
LISTED



Department of Business Affairs and Consumer Protection  
Small Business Center - Public Way Use Unit  
City Hall - 121 N. LaSalle Street, Room 800 • Chicago, IL 60602  
(312)-74-GOBIZ (312-744-6249) • (312) 744-1944 (TTY)  
<http://www.cityofchicago.org/bacp>

03/05/2014

Alderman **Harry Osterman**

Ward # **48**

City of Chicago

City Hall, Room **300**

121 North LaSalle Street

Chicago, Illinois 60602

Re: An ordinance to use and maintain a portion of the public right-of-way for **one (1) sign(s)** for **NORTH SHORE AUTO SERVICE INC**, adjacent to the premises known as **6240 N. Broadway**.

Dear Alderman **Harry Osterman**:

The applicant referenced above has requested the use of the public right-of-way for a **sign(s)**. An ordinance has been prepared by the Department of Business Affairs and Consumer Protection – Small Business Center - Public Way Use Unit for presentation to the City Council. Because this request was made for properties located in your ward, as approved by you as per the attached, I respectfully request that you introduce the attached ordinance at the next City Council meeting.

If you have any questions regarding this ordinance, please contact Anthony Bertuca at (312) 744-5506.

**Department of Business Affairs and Consumer Protection**