



City of Chicago



O2021-30

Office of the City Clerk

Document Tracking Sheet

Meeting Date:	1/20/2021
Sponsor(s):	King (4)
Type:	Ordinance
Title:	Grant(s) of privilege in public way for Pure Barre Chicago Hyde Park
Committee(s) Assignment:	Committee on Transportation and Public Way

Direct Intro

#4

ORDINANCE

Pure Barre Chicago Hyde Park
Acct. No. 467577 - 1
Permit No. 1146928

Be It Ordained by the City Council of the City of Chicago:

SECTION 1. Permission and authority are hereby given and granted to Pure Barre Chicago Hyde Park, upon the terms and subject to the conditions of this ordinance to maintain and use one (1) sign(s) projecting over the public right-of-way attached to its premises known as 5239 S. Harper Ave..

Said sign structure(s) measures as follows; along S Harper Ave:

One (1) at two (2) feet in length, one point five (1.5) feet in height and ten (10) feet above grade level.

The location of said privilege shall be as shown on prints kept on file with the Department of Business Affairs and Consumer Protection and the Office of the City Clerk.

Said privilege shall be constructed in accordance with plans and specifications approved by the Department of Transportation (Division of Project Development) and Zoning Department - Signs.

This grant of privilege in the public way shall be subject to the provisions of Section 10-28-015 and all other required provisions of the Municipal Code of Chicago.

The grantee shall pay to the City of Chicago as compensation for the privilege #1146928 herein granted the sum of one hundred (\$100.00) per annum in advance.

A 25% penalty will be added for payments received after due date.

The permit holder agrees to hold the City of Chicago harmless for any damage, relocation or replacement costs associated with damage, relocation or removal of private property caused by the City performing work in the public way.

Authority herein given and granted for a period of five (5) years from and after Date of Passage.

Alderman _____

Sophia King 4th Ward

Pure Barre (5239 S Harper Ave Chicago IL)

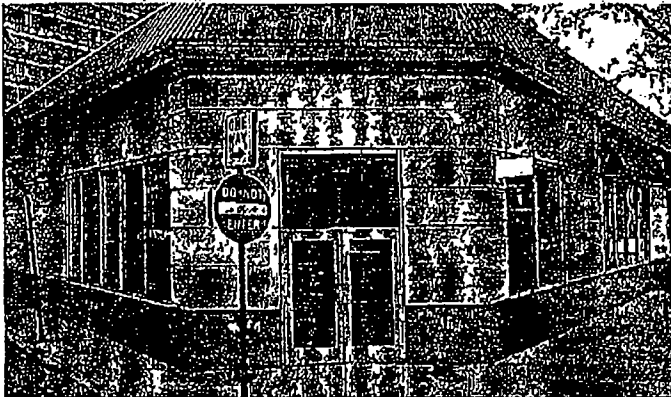
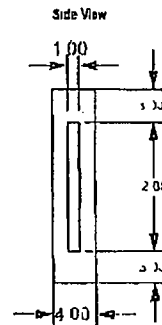
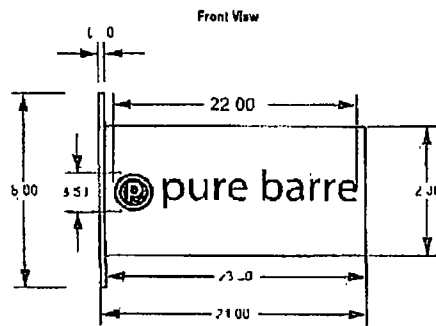

Double sided Non illuminated Blade Sign
 Quantity One(1)
 Material Aluminum panel painted white
 Overall Height 12 0
 Overall Length 24 0
 Total Sq Ft 2 0 ft

PURE BARRE logo and letters
 Material 3mm Acrylic Pantone 1797 C Red
 Overall Height 3 59
 Overall Length 22 0
 Total Sq Ft 0 55 ft

Mounting
 Material 4 x 18 x 1/2 Mounting plate

Sign will be anchored to building centered between 6th and 7th coursing (from bottom)

PLEASE REVIEW DRAWINGS FOR ACCURACY IN COLOR, LAYOUT, SPELLING, APPROVAL STATE ALL CONTENT IS PRESENTED TO YOU FOR YOUR REVIEW

<p>5510 N. State St. Chicago, IL 60630 773.267.6407 sales@tfsigns.com</p>	Client Name: Pure Barre	Start Date: 11/21/2020	Sales Rep: Seung Park Designer: Ed Matena
	Location: 5239 S Harper Ave, Chicago Illinois USA	Last Revision: 11/21/2020 Drawing#: Page: 1 of 2	



Department of Business Affairs and Consumer Protection
Small Business Center - Public Way Use Unit
City Hall - 121 N. LaSalle Street, Room 800 • Chicago, IL 60602
312-74-GOBIZ / 312-744-6249 • (312) 744-1944 (TTY)
<http://www.cityofchicago.org/bacp>

12/16/2020

Alderman **Sophia King**
Ward # 04
City of Chicago
City Hall, Room 305
121 North LaSalle Street
Chicago, Illinois 60602

Re: An ordinance to use and maintain a portion of the public right-of-way for **one (1) sign(s)** for **Pure Barre Chicago Hyde Park**, adjacent to the premises known as **5239 S. Harper Ave.**.

Dear Alderman **Sophia King**:

The applicant referenced above has requested the use of the public right-of-way for a **sign(s)**. An ordinance has been prepared by the Department of Business Affairs and Consumer Protection – Small Business Center - Public Way Use Unit for presentation to the City Council. Because this request was made for properties located in your ward, as approved by you as per the attached, I respectfully request that you introduce the attached ordinance at the next City Council meeting.

If you have any questions regarding this ordinance, please contact Anthony Bertuca at (312) 744-5506.

Department of Business Affairs and Consumer Protection