



City of Chicago



O2016-6739

Office of the City Clerk

Document Tracking Sheet

Meeting Date:	9/14/2016
Sponsor(s):	Pawar (47)
Type:	Ordinance
Title:	Awning(s) for Boutique Cleaners
Committee(s) Assignment:	Committee on Transportation and Public Way

ORDINANCE
BOUTIQUE CLEANERS
Acct. No. 405317 - 1
Permit No. 1122854

Be It Ordained by the City Council of the City of Chicago:

SECTION 1. Permission and authority are hereby given and granted to BOUTIQUE CLEANERS, upon the terms and subject to the conditions of this ordinance to construct, install, maintain and use one (1) Awning(s) projecting over the public right-of-way adjacent to its premises known as 3405 N. Paulina St..

Said Awning(s) at N. Paulina measure(s):

One (1) at thirteen (13) feet in length, and four (4) feet in width for a total of fifty-two (52) square feet.

The location of said privilege shall be as shown on prints kept on file with the Department of Business Affairs and Consumer Protection and the Office of the City Clerk.

Said privilege shall be constructed in accordance with plans and specifications approved by the Zoning Department - Signs.

This grant of privilege in the public way shall be subject to the provisions of Section 10-28-015 and all other required provisions of the Municipal Code of Chicago.

The grantee shall pay to the City of Chicago as compensation for the privilege #1122854 herein granted the sum of fifty (\$50.00) per annum in advance.

A 25% penalty will be added for payments received after due date.

The permit holder agrees to hold the City of Chicago harmless for any damage, relocation or replacement costs associated with damage, relocation or removal of private property caused by the City performing work in the public way.

Authority herein given and granted for a period of five (5) years from and after Date of Passage.

Alderman  _____
Ameya Pawar 47th Ward

■ AWNING ON FRONT OF WALL

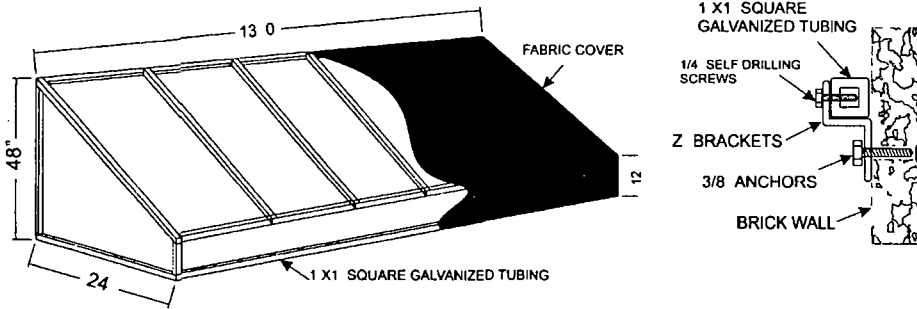
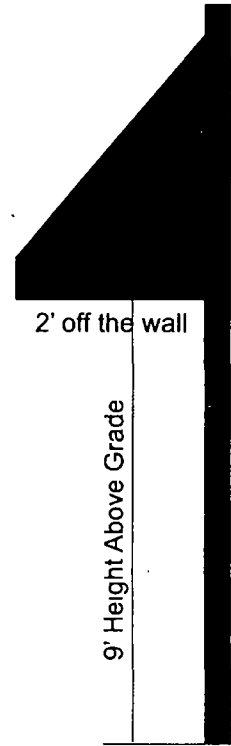

* Don't drill on teracota

 5500 N. Kedzie Ave Chicago, IL 60625 773-267-6007 sales@tfasigns.com	Client <u>Boutique Cleaners</u>	Landlord _____	Start Date <u>00/00/0000</u>	• Client Approval • Landlord Approval	Sales Rep Seung Park Designer
	Address <u>3405 N Paulina</u>	Address _____	Last Revision <u>00/00/0000</u>		Job# <u>00000</u> Drawing# <u>00000a v1 s1 / e1</u> Page 1 of 2
Tel _____	Tel _____				
Email _____	Email _____				

COPYRIGHT 2013 BY TFA Signs THIS RENDERING IS THE PROPERTY OF TFA SIGNS INC AND THE PARTY WHICH REQUESTED THE RENDERING IT IS AN UNPUBLISHED ORIGINAL DRAWING NOT TO BE REPRODUCED OR EXHIBITED WITHOUT THE CONSENT OF TFA SIGNS INC



09/14/2016

Alderman **Ameya Pawar**
Ward # 47
City of Chicago
City Hall, Room 200
121 North LaSalle Street
Chicago, Illinois 60602

Re: An ordinance to use and maintain a portion of the public right-of-way for **one (1) awning(s)** for **BOUTIQUE CLEANERS**, adjacent to the premises known as **3405 N. Paulina St.**

Dear Alderman **Ameya Pawar**:

The applicant referenced above has requested the use of the public right-of-way for a **awning(s)**. An ordinance has been prepared by the Department of Business Affairs and Consumer Protection – Small Business Center - Public Way Use Unit for presentation to the City Council. Because this request was made for properties located in your ward, as approved by you as per the attached, I respectfully request that you introduce the attached ordinance at the next City Council meeting.

If you have any questions regarding this ordinance, please contact Anthony Bertuca at (312) 744-5506.

Department of Business Affairs and Consumer Protection