



Office of Chicago City Clerk



O2011-1182

Office of the City Clerk

City Council Document Tracking Sheet

Meeting Date:	2/9/2011
Status:	Introduced
Sponsor(s):	Brookins, Howard (21)
Type:	Ordinance
Title:	Grant(s) of Privilege in Public Way for CMK Realty LLC
Committee(s) Assignment:	Committee on Transportation and Public Way

ORDINANCE
W2005 CMK REALTY LLC
Acct. No. 299160 - 1
Permit No. 1095071

Be It Ordained by the City Council of the City of Chicago:

SECTION 1. Permission and authority are hereby given and granted to W2005 CMK REALTY LLC, upon the terms and subject to the conditions of this ordinance to maintain and use one (1) sign(s) projecting over the public right-of-way attached to its premises known as 301 W. 83rd St..

Said sign structure(s) measures as follows; along Holland Rd:
One (1) at sixty-six (66) feet in length, twenty-three (23) feet in height and twenty-one point five (21.5) feet above grade level.

The location of said privilege shall be as shown on prints kept on file with the Department of Business Affairs and Consumer Protection and the Office of the City Clerk.

Said privilege shall be constructed in accordance with plans and specifications approved by the Zoning Department - Signs.

This grant of privilege in the public way shall be subject to the provisions of Section 10-28-015 and all other required provisions of the Municipal Code of Chicago.

The grantee shall pay to the City of Chicago as compensation for the privilege #1095071 herein granted the sum of three hundred (\$300.00) per annum in advance.

A 25% penalty will be added for payments received after due date.

The permit holder agrees to hold the City of Chicago harmless for any damage, relocation or replacement costs associated with damage, relocation or removal of private property caused by the City performing work in the public way.

Authority herein given and granted for a period of five (5) years from and after 02/08/2011.

Alderman 

Howard Brookins, Jr. 21st Ward

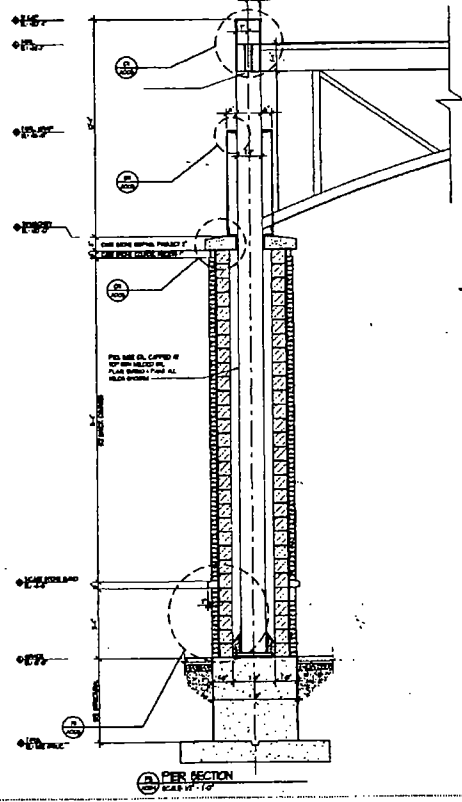
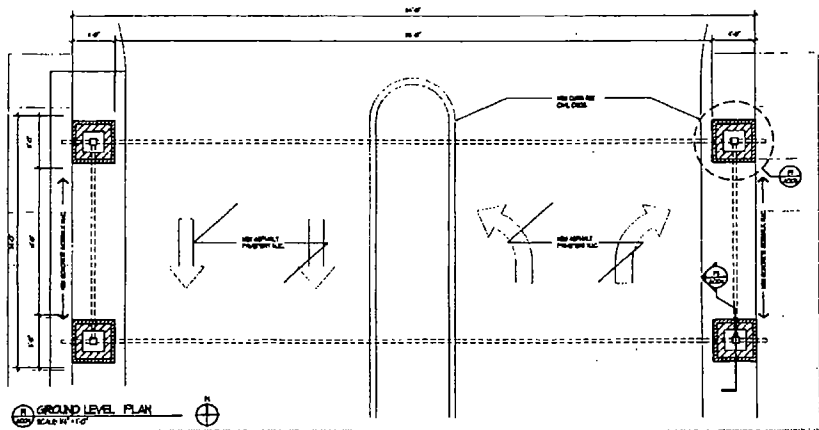
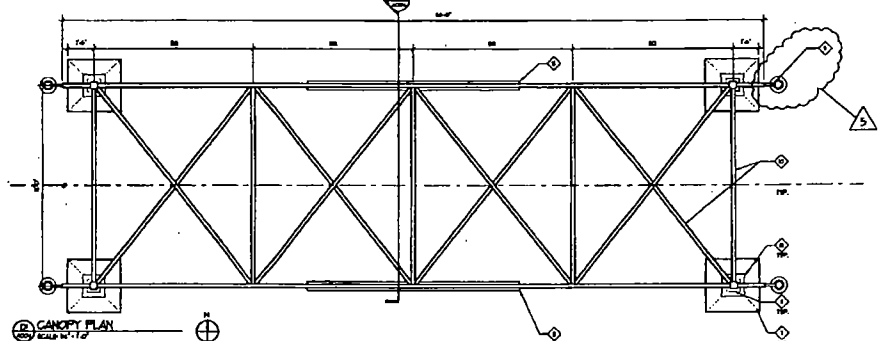
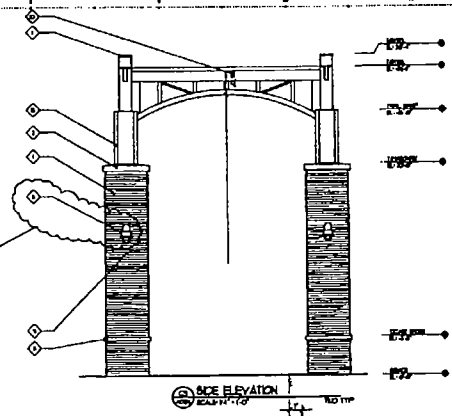
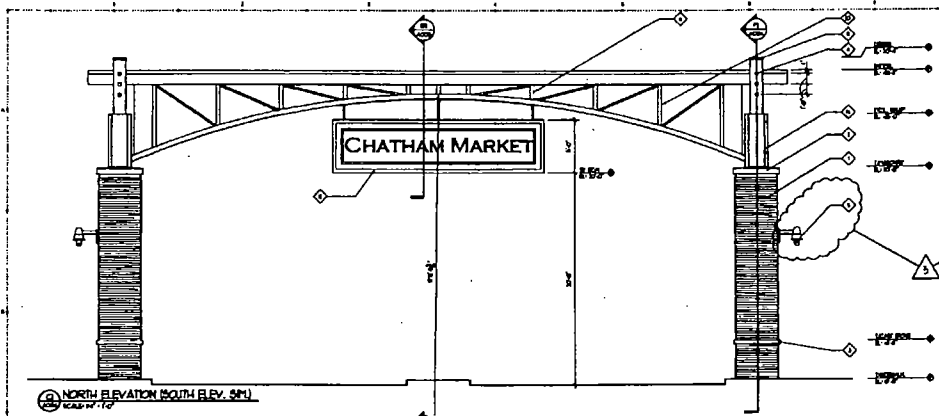

KEY NOTES

1. MODULAR FACE BRICK
2. CAST IRON CAPITAL
3. CAST IRON BALL
4. 1/2" DIA. HUBS BRACED TO BR.
5. 1/2" DIA. HUBS BRACED TO BR.
6. 1/2" DIA. HUBS BRACED TO BR.
7. 1/2" DIA. HUBS BRACED TO BR.
8. 1/2" DIA. HUBS BRACED TO BR.
9. 1/2" DIA. HUBS BRACED TO BR.
10. 1/2" DIA. HUBS BRACED TO BR.
11. 1/2" DIA. HUBS BRACED TO BR.
12. 1/2" DIA. HUBS BRACED TO BR.
13. 1/2" DIA. HUBS BRACED TO BR.
14. 1/2" DIA. HUBS BRACED TO BR.
15. 1/2" DIA. HUBS BRACED TO BR.
16. 1/2" DIA. HUBS BRACED TO BR.
17. 1/2" DIA. HUBS BRACED TO BR.
18. 1/2" DIA. HUBS BRACED TO BR.
19. 1/2" DIA. HUBS BRACED TO BR.
20. 1/2" DIA. HUBS BRACED TO BR.

NOTES TO DRAWING

1. SEE GENERAL NOTES
2. SEE GENERAL NOTES
3. SEE GENERAL NOTES
4. SEE GENERAL NOTES
5. SEE GENERAL NOTES
6. SEE GENERAL NOTES
7. SEE GENERAL NOTES
8. SEE GENERAL NOTES
9. SEE GENERAL NOTES
10. SEE GENERAL NOTES
11. SEE GENERAL NOTES
12. SEE GENERAL NOTES
13. SEE GENERAL NOTES
14. SEE GENERAL NOTES
15. SEE GENERAL NOTES
16. SEE GENERAL NOTES
17. SEE GENERAL NOTES
18. SEE GENERAL NOTES
19. SEE GENERAL NOTES
20. SEE GENERAL NOTES



O&W
O'CONNELL & WALSH
 ARCHITECTS
 100 N. EAST ST. 10TH FLOOR
 CHICAGO, ILL. 60602
 TEL: 312.527.1100
 FAX: 312.527.1101

CHATHAM MARKET
GATEWAY
 PLAN, ELEVATION
 AND SECTION

DESIGNED BY: J. J. O'CONNELL
 DRAWN BY: J. J. O'CONNELL
 DATE: 11/13/00
 SCALE: 1/4" = 1'-0"
 SHEET NO.: 08004
A004



02/09/2011

Alderman Howard Brookins, Jr.
Ward # 21
City of Chicago
City Hall, Room 300
121 North LaSalle Street
Chicago, Illinois 60602

Re: An ordinance to use and maintain a portion of the public right-of-way for one (1) sign(s) for **W2005 CMK REALTY LLC**, adjacent to the premises known as **301 W. 83rd St.**

Dear Alderman Howard Brookins, Jr.:

The applicant referenced above has requested the use of the public right-of-way for a sign(s). An ordinance has been prepared by the Department of Business Affairs and Consumer Protection – Business Assistance Center - Public Way Use Unit for presentation to the City Council. Because this request was made for properties located in your ward, as approved by you as per the attached, I respectfully request that you introduce the attached ordinance at the next City Council meeting.

If you have any questions regarding this ordinance, please contact John Mariane, Manager, Business Assistance Center - Public Way Use Unit, at (312) 744-2063.

Very truly yours,

A handwritten signature in black ink that reads "Norma I. Reyes".

Norma I. Reyes
Commissioner
Department of Business Affairs and Consumer Protection

NIR/sl

APPLICATION TO USE THE PUBLIC RIGHT OF WAY

APPLICANT INFORMATION:

NAME: W2005 Cmk Realty LLC

ACCT#: 299160 RENEWAL SITE#: 1

PERMIT#: 1047596

ADDRESS: 71 S. Wacker Dr., Apt./Suite 2110

ZIP CODE: 60606

CONTACT PERSON: Bill Moston

TITLE: PHONE: (312)629-7801

Check box for change of mailing address. Provide information below
c/o Monroe Asset Management
New Mailing Address: 30 W. Monroe St. Suite 1000
Phone: (312)377-8356
Contact: Tom Brasler

Note: Any changes to ownership requires a new application.

If no changes, complete applicant certification, obtain Alderman's signature, include photo(s) and sketch as described below. Return to:

City of Chicago
Department of Business Affairs and Consumer Protection
Business Assistance Center - Public Way Use Unit
City Hall - 121 N. LaSalle Street, Room 800
Chicago, IL 60602
(312)-74-GOBIZ (312-744-6249)

USE OF THE PUBLIC WAY

Type How Many? Building Address

Sign	1	301 W. 83RD ST.
------	---	-----------------

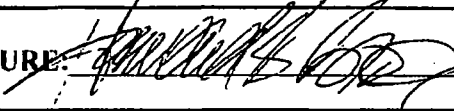
ALDERMAN'S SIGNATURE:  WARD: 21 DATE: 2/3/11

