



City of Chicago



O2014-4491

Office of the City Clerk

Document Tracking Sheet

| | |
|---------------------------------|--|
| Meeting Date: | 5/28/2014 |
| Sponsor(s): | Waguespack (32) |
| Type: | Ordinance |
| Title: | Awning(s) for Peek, Aren't You Curious, Inc. |
| Committee(s) Assignment: | Committee on Transportation and Public Way |

ORDINANCE
PEEK, AREN'T YOU CURIOUS, INC
Acct. No. 389797 - 1
Permit No. 1112663

Be It Ordained by the City Council of the City of Chicago:

SECTION 1. Permission and authority are hereby given and granted to PEEK, AREN'T YOU CURIOUS, INC, upon the terms and subject to the conditions of this ordinance to construct, install, maintain and use one (1) Awning(s) projecting over the public right-of-way adjacent to its premises known as 1723 N. Damen Ave..

Said Awning(s) at Damen measure(s):

One (1) at twenty point five eight (20.58) feet in length, and three point three three (3.33) feet in width for a total of sixty-eight point five three (68.53) square feet.

The location of said privilege shall be as shown on prints kept on file with the Department of Business Affairs and Consumer Protection and the Office of the City Clerk.

Said privilege shall be constructed in accordance with plans and specifications approved by the Zoning Department - Signs.

This grant of privilege in the public way shall be subject to the provisions of Section 10-28-015 and all other required provisions of the Municipal Code of Chicago.

The grantee shall pay to the City of Chicago as compensation for the privilege #1112663 herein granted the sum of fifty (\$50.00) per annum in advance.

A 25% penalty will be added for payments received after due date.

The permit holder agrees to hold the City of Chicago harmless for any damage, relocation or replacement costs associated with damage, relocation or removal of private property caused by the City performing work in the public way.

Authority herein given and granted for a period of five (5) years from and after Date of Passage.

Alderman 
Scott Waguespack 32nd Ward

Handwritten signature or scribble.

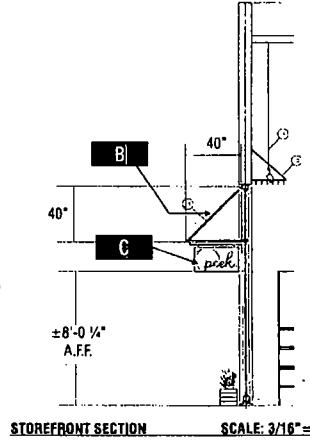
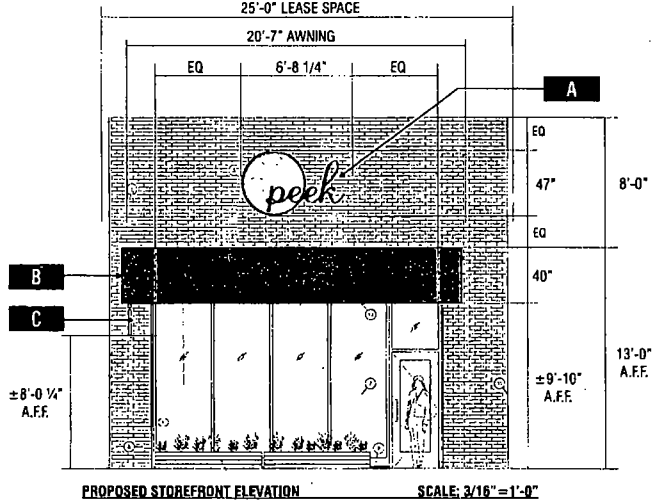
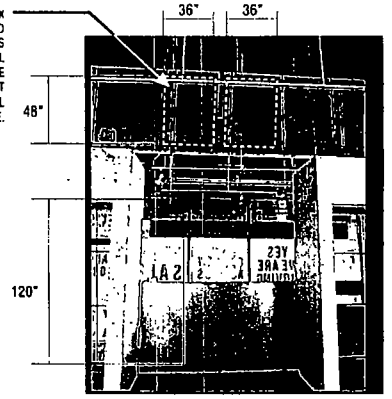
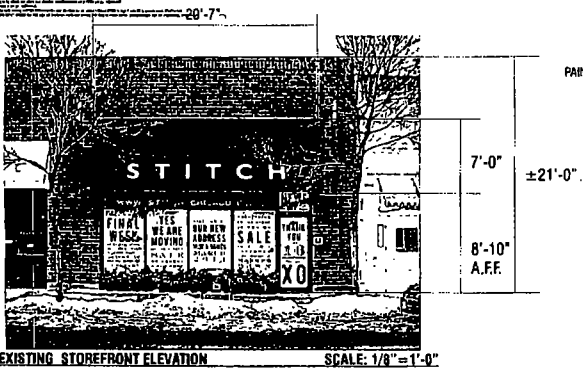

Signtech

4444 Federal Blvd. San Diego CA 92182
 Phone (619) 527-4109 / Fax: (619) 527-4111
 www.signtechUSA.com



Peek...Aren't You Curious

1723 North Damen Ave
 Chicago, IL 60647

Initial Date: 03/19/14
 Salesperson: Matthew Thompson
 Coordinator: Gladys Ojeda
 Designer: Svetlana Mladynov
 Scale: As noted

CUSTOMER APPROVAL

Customer Signature _____ Date _____
 COPY COLORS & SIZES

Signtech does NOT provide primary electrical to sign location - **RESPONSIBILITY OF OTHERS!**

Customer Signature _____ Date _____

This design is the exclusive property of Signtech and cannot be reproduced in whole or in part, without their prior written approval.

Drawing Number: 14-00410
 Work Order Number: 62198



05/28/2014

Alderman **Scott Waguespack**
Ward # **32**
City of Chicago
City Hall, Room **300**
121 North LaSalle Street
Chicago, Illinois 60602

Re: An ordinance to use and maintain a portion of the public right-of-way for **one (1) awning(s)** for
PEEK, AREN'T YOU CURIOUS, INC, adjacent to the premises known as **1723 N. Damen Ave.**.

Dear Alderman **Scott Waguespack**:

The applicant referenced above has requested the use of the public right-of-way for a **awning(s)**. An ordinance has been prepared by the Department of Business Affairs and Consumer Protection – Small Business Center - Public Way Use Unit for presentation to the City Council. Because this request was made for properties located in your ward, as approved by you as per the attached, I respectfully request that you introduce the attached ordinance at the next City Council meeting.

If you have any questions regarding this ordinance, please contact Anthony Bertuca at (312) 744-5506.

Department of Business Affairs and Consumer Protection