



# City of Chicago



O2017-2715

Office of the City Clerk

## Document Tracking Sheet

<b>Meeting Date:</b>	3/29/2017
<b>Sponsor(s):</b>	Ramirez-Rosa (35)
<b>Type:</b>	Ordinance
<b>Title:</b>	Grant(s) of privilege in public way for Tony's Finer Foods Enterprises, Inc. - security camera
<b>Committee(s) Assignment:</b>	Committee on Transportation and Public Way

ORDINANCE  
TONY'S FINER FOODS ENTERPRISES, INC.  
Acct. No. 305203 - 1  
Permit No. 1125898

*Be It Ordained by the City Council of the City of Chicago:*

SECTION 1. Permission and authority are hereby given and granted to TONY'S FINER FOODS ENTERPRISES, INC., upon the terms and subject to the conditions of this ordinance to construct, install, maintain and use two (2) Security Camera(s) projecting over the public right-of-way for security purposes adjacent to its premises known as 3607 W. Fullerton Ave..

Said Security Camera(s) at W. Fullerton Avenue measure(s):  
One (1) at one (1) foot in length, one (1) foot in width and seventeen (17) feet above grade level.

Said Security Camera(s) at N. Central Park Avenue measure(s):  
One (1) at point eight three (.83) feet in length, point eight three (.83) feet in width and twelve (12) feet above grade level.

The location of said privilege shall be as shown on prints kept on file with the Department of Business Affairs and Consumer Protection and the Office of the City Clerk.

Said privilege shall be constructed in accordance with plans and specifications approved by the Department of Planning and Development and Department of Transportation (Division of Project Development).

This grant of privilege in the public way shall be subject to the provisions of Section 10-28-015 and all other required provisions of the Municipal Code of Chicago.

The grantee shall pay to the City of Chicago as compensation for the privilege #1125898 herein granted the sum of zero (\$.00) per annum in advance.

A 25% penalty will be added for payments received after due date.

The permit holder agrees to hold the City of Chicago harmless for any damage, relocation or replacement costs associated with damage, relocation or removal of private property caused by the City performing work in the public way.

Authority herein given and granted for a period of five (5) years from and after Date of Passage.

Alderman  \_\_\_\_\_  
Carlos Ramirez-Rosa 35th Ward

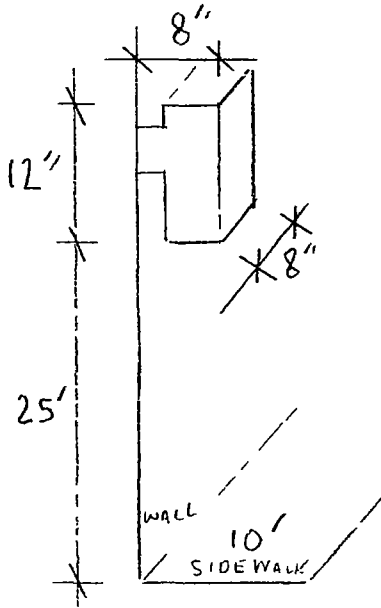

SIX LIGHT FIXTURES  
NORTH WALL OF BUILDING

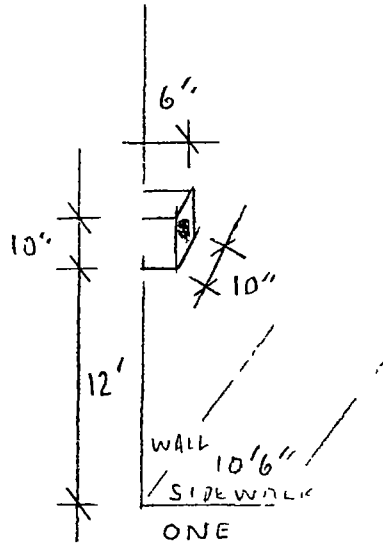

ONE  
CAMERA  
SOUTH  
CORNER  
BUILDING

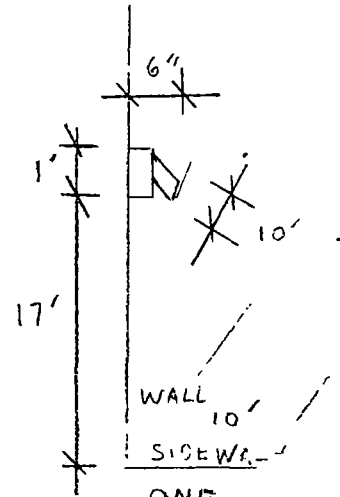

ONE  
CAMERA  
NORTHWEST  
CORNER OF  
BUILDING

1-13-17

TONY'S FINE FOODS  
3607 W FULLERTON  
CHICAGO