



# Office of the City Clerk



O2013-3047

Office of the City Clerk

## City Council Document Tracking Sheet

|                                 |   |
|---------------------------------|---|
| <b>Meeting Date:</b>            | 4/10/2013   |
| <b>Sponsor(s):</b>              | Sposato, Nicholas (36)                            |
| <b>Type:</b>                    | Ordinance   |
| <b>Title:</b>                   | Grant(s) of privilege in public way for Tots Land |
| <b>Committee(s) Assignment:</b> | Committee on Transportation and Public Way        |

ORDINANCE  
TOTS LAND  
Acct. No. 345318 - 2  
Permit No. 1103955

*Be It Ordained by the City Council of the City of Chicago:*

SECTION 1. Permission and authority are hereby given and granted to TOTS LAND, upon the terms and subject to the conditions of this ordinance to maintain and use one (1) sign(s) projecting over the public right-of-way attached to its premises known as 2639 N. Harlem Ave..

Said sign structure(s) measures as follows; along N HARLEM AVE:

One (1) at twenty (20) feet in length, three (3) feet in height and ten point five eight (10.58) feet above grade level.

The location of said privilege shall be as shown on prints kept on file with the Department of Business Affairs and Consumer Protection and the Office of the City Clerk.

Said privilege shall be constructed in accordance with plans and specifications approved by the Department of Transportation (Division of Project Development) and Zoning Department - Signs.

This grant of privilege in the public way shall be subject to the provisions of Section 10-28-015 and all other required provisions of the Municipal Code of Chicago.

The grantee shall pay to the City of Chicago as compensation for the privilege #1103955 herein granted the sum of three hundred (\$300.00) per annum in advance.

A 25% penalty will be added for payments received after due date.

The permit holder agrees to hold the City of Chicago harmless for any damage, relocation or replacement costs associated with damage, relocation or removal of private property caused by the City performing work in the public way.

Authority herein given and granted for a period of five (5) years from and after Date of Passage.

Alderman 

Nicholas Sposato 36<sup>th</sup> Ward

# APPLICATION TO USE THE PUBLIC RIGHT OF WAY

## 2639 N HARLEM AVE

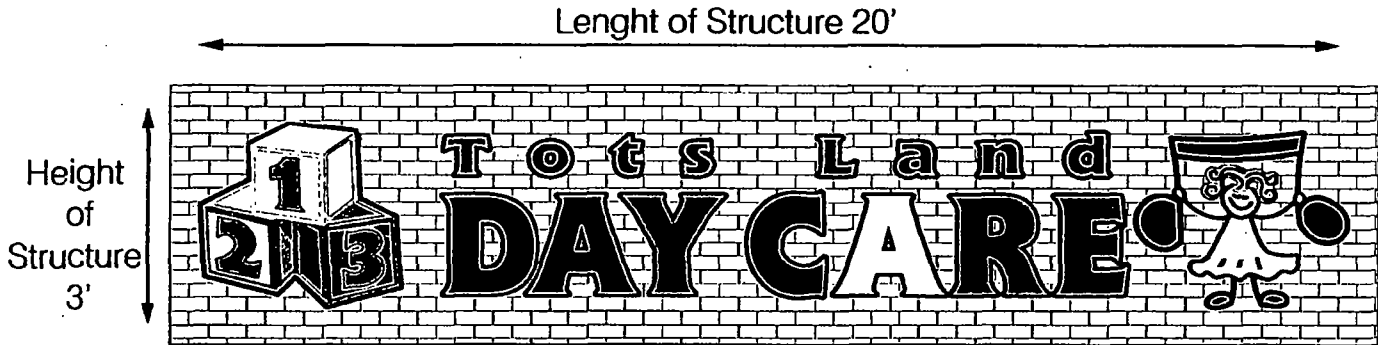

### Total Depth over Public Way 1/2"

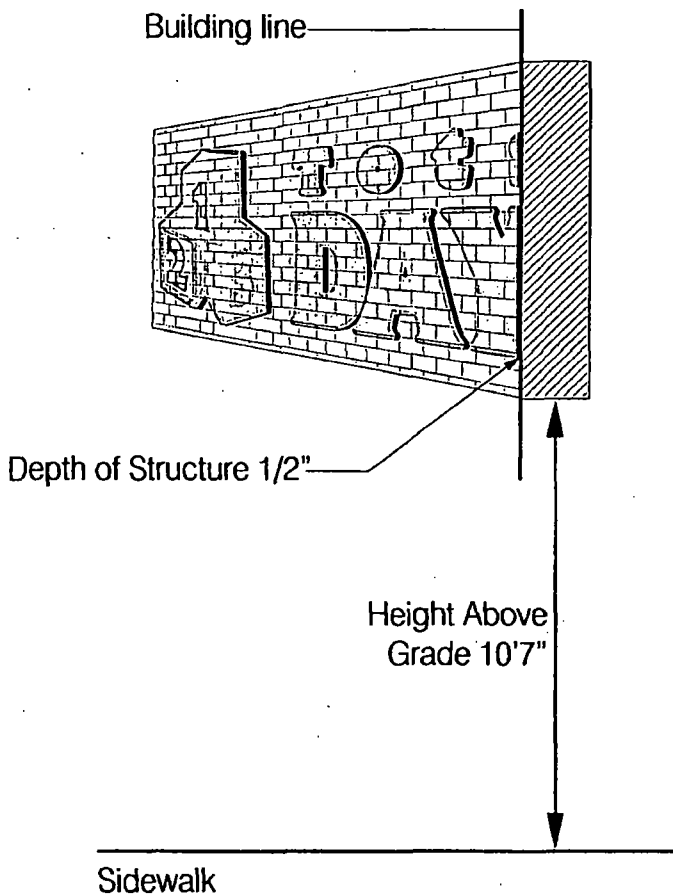

#### Sign Structure by Layers

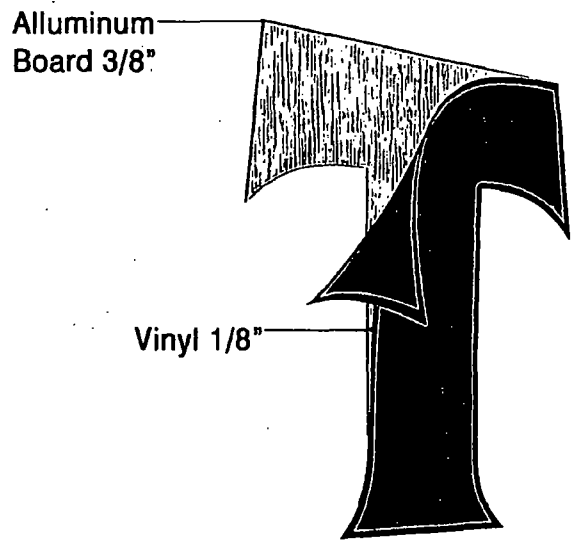



**04/10/2013**

**Alderman Nicholas Sposato**  
Ward # 36  
City of Chicago  
City Hall, Room 304  
121 North LaSalle Street  
Chicago, Illinois 60602

Re: An ordinance to use and maintain a portion of the public right-of-way for **one (1) sign(s)** for **TOTS LAND**, adjacent to the premises known as **2639 N. Harlem Ave.**.

Dear Alderman **Nicholas Sposato**:

The applicant referenced above has requested the use of the public right-of-way for a **sign(s)**. An ordinance has been prepared by the Department of Business Affairs and Consumer Protection – Business Assistance Center - Public Way Use Unit for presentation to the City Council. Because this request was made for properties located in your ward, as approved by you as per the attached, I respectfully request that you introduce the attached ordinance at the next City Council meeting.

If you have any questions regarding this ordinance, please contact Anthony Bertuca at (312) 744-5506.

**Department of Business Affairs and Consumer Protection**