



City of Chicago



O2016-219

Office of the City Clerk

Document Tracking Sheet

Meeting Date:	1/13/2016
Sponsor(s):	Hopkins (2)
Type:	Ordinance
Title:	Awning(s) for Drybar Holdings LLC
Committee(s) Assignment:	Committee on Transportation and Public Way

ORDINANCE
DRYBAR HOLDINGS LLC
Acct. No. 384732 - 3
Permit No. 1120661

Be It Ordained by the City Council of the City of Chicago:

SECTION 1. Permission and authority are hereby given and granted to DRYBAR HOLDINGS LLC, upon the terms and subject to the conditions of this ordinance to construct, install, maintain and use one (1) Awning(s) projecting over the public right-of-way adjacent to its premises known as 755 N. Wells St..

Said Awning(s) at N. Wells Street measure(s):

One (1) at ten point three three (10.33) feet in length, and one point five (1.5) foot in width for a total of fifteen point five (15.5) square feet.

The location of said privilege shall be as shown on prints kept on file with the Department of Business Affairs and Consumer Protection and the Office of the City Clerk.

Said privilege shall be constructed in accordance with plans and specifications approved by the Zoning Department - Signs.

This grant of privilege in the public way shall be subject to the provisions of Section 10-28-015 and all other required provisions of the Municipal Code of Chicago.

The grantee shall pay to the City of Chicago as compensation for the privilege #1120661 herein granted the sum of fifty (\$50.00) per annum in advance.

A 25% penalty will be added for payments received after due date.

The permit holder agrees to hold the City of Chicago harmless for any damage, relocation or replacement costs associated with damage, relocation or removal of private property caused by the City performing work in the public way.

Authority herein given and granted for a period of five (5) years from and after Date of Passage.

Alderman _____

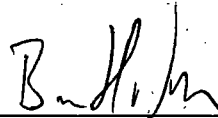

Brian Hopkins 2nd Ward

QUANTITY: 1
 ILLUMINATION: NONE
 FACE:
 CLOSE ENDED FABRIC AWNING
 S. UMBRELLA 14684 SLATE
 FLAME TREATED,
 BOTTOM OF AWNINGS
 ARE OPEN
 MOUNTING:
 MECHANICALLY FASTENED

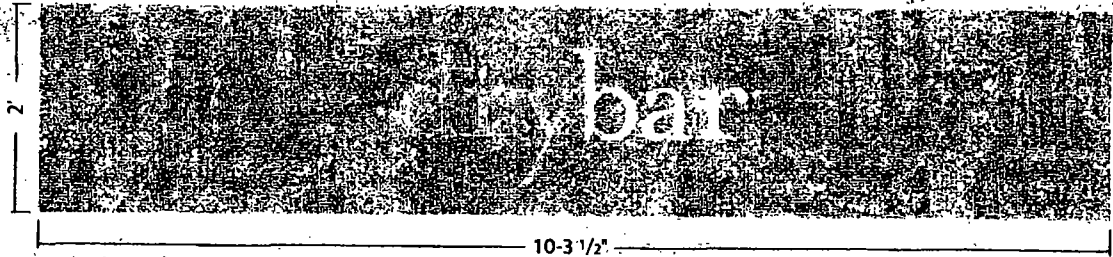

PRINTED AWNING
QTY: 1

BLANK AWNINGS - QTY: 5 TOTAL
2 @ - 10' - 3 1/2" WIDE
2 @ - 10' - 7" WIDE
1 @ - 10' - 8 1/2" WIDE

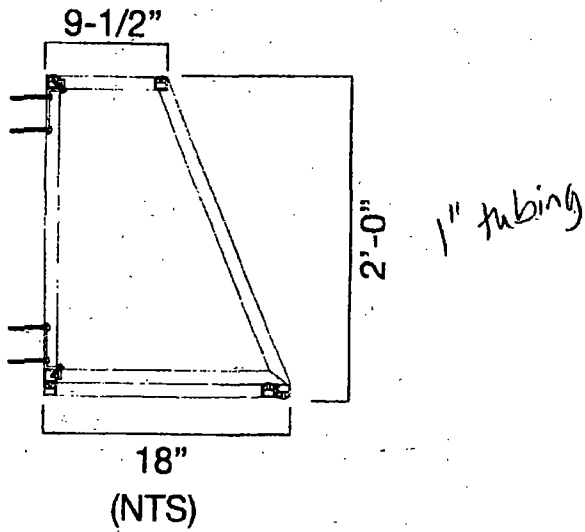

Client Information: CHEVELLA - BEVIER NORTH 755 NORTH WELLS CHICAGO, IL	Project: 6016
Date of this drawing: 11/10/11 Drawn by: [Signature] Checked by: [Signature] Designated by: [Signature] Approved by: [Signature]	680Design



01/13/2016

Alderman Brian Hopkins
Ward # **02**
City of Chicago
City Hall, Room **200**
121 North LaSalle Street
Chicago, Illinois 60602

Re: An ordinance to use and maintain a portion of the public right-of-way for **one (1) awning(s)** for **DRYBAR HOLDINGS LLC**, adjacent to the premises known as **755 N. Wells St.**.

Dear Alderman **Brian Hopkins**:

The applicant referenced above has requested the use of the public right-of-way for a **awning(s)**. An ordinance has been prepared by the Department of Business Affairs and Consumer Protection – Small Business Center - Public Way Use Unit for presentation to the City Council. Because this request was made for properties located in your ward, as approved by you as per the attached, I respectfully request that you introduce the attached ordinance at the next City Council meeting.

If you have any questions regarding this ordinance, please contact Anthony Bertuca at (312) 744-5506.

Department of Business Affairs and Consumer Protection