



City of Chicago



O2016-2168

Office of the City Clerk

Document Tracking Sheet

Meeting Date:	3/16/2016
Sponsor(s):	Reilly (42)
Type:	Ordinance
Title:	Grant(s) of privilege in public way for Illinois Franklin LLC - tree grates
Committee(s) Assignment:	Committee on Transportation and Public Way

ORDINANCE
Illinois Franklin LLC
Acct. No. 404040 - 1
Permit No. 1121752

Be It Ordained by the City Council of the City of Chicago:

SECTION 1. Permission and authority are hereby given and granted to Illinois Franklin LLC, upon the terms and subject to the conditions of this ordinance to construct, install, maintain and use five (5) Tree Grates(s) on the public right-of-way adjacent to its premises known as 311 W. Illinois St..

Said Tree Grates(s) at W. Illinois measure(s):

Five (5) at ten (10) feet in length, and five (5) feet in width for a total of two hundred fifty (250) square feet.

The location of said privilege shall be as shown on prints kept on file with the Department of Business Affairs and Consumer Protection and the Office of the City Clerk.

Said privilege shall be constructed in accordance with plans and specifications approved by the Department of Planning and Development and Department of Transportation (Division of Project Development).

This grant of privilege in the public way shall be subject to the provisions of Section 10-28-015 and all other required provisions of the Municipal Code of Chicago.

The grantee shall pay to the City of Chicago as compensation for the privilege #1121752 herein granted the sum of zero (\$0.00) per annum in advance.

A 25% penalty will be added for payments received after due date.

The permit holder agrees to hold the City of Chicago harmless for any damage, relocation or replacement costs associated with damage, relocation or removal of private property caused by the City performing work in the public way.

Authority herein given and granted for a period of five (5) years from and after Date of Passage.

Alderman _____

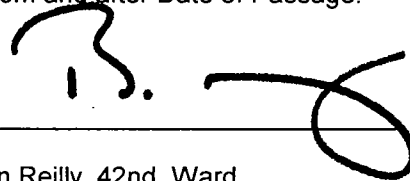

Brendan Reilly 42nd Ward

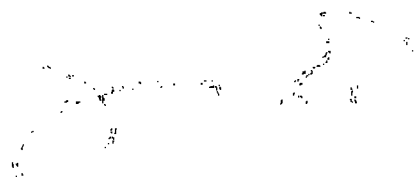

FitzGerald
Associates Architects
TREE GRATE SITE PLAN

SELEVEN
14175
11/24/15

ASK-01

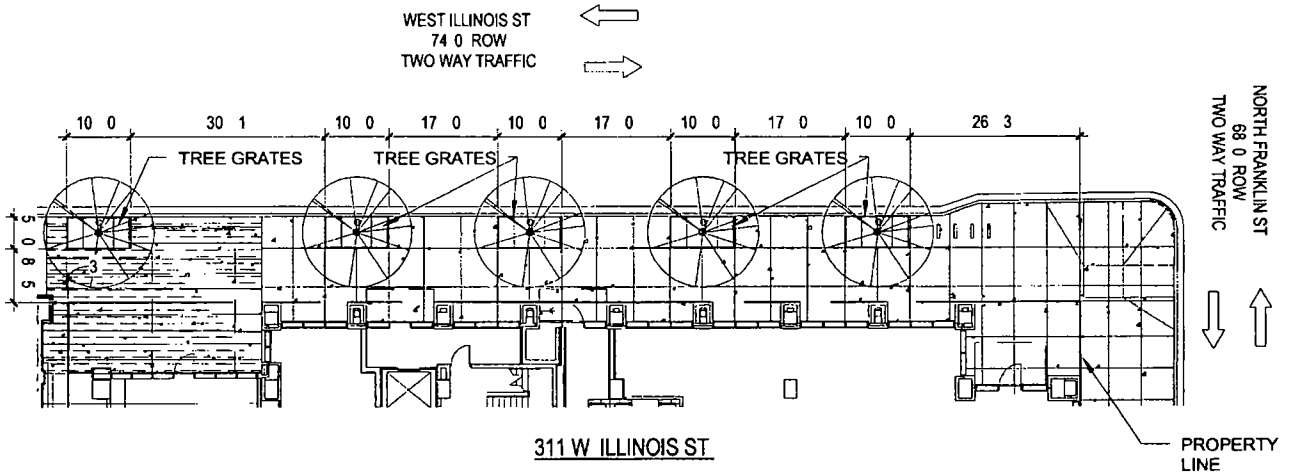

NEW TYPE I A 24 STORY HIGH RISE FULLY SPRINKLERED
CLASS A 2 MULTIPLE DWELLINGS WITH 19 STORIES OF
APARTMENTS ABOVE GROUND FLOOR RETAIL AND AN
AUXILIARY 109 RESIDENT PARKING SPACES ON FLOORS 2
4 EXTENSION

