



City of Chicago



O2016-2014

Office of the City Clerk

Document Tracking Sheet

Meeting Date:	3/16/2016
Sponsor(s):	Zalewski (23)
Type:	Ordinance
Title:	Grant(s) of privilege in public way for General Nutrition Center No. 61
Committee(s) Assignment:	Committee on Transportation and Public Way

ORDINANCE
GENERAL NUTRITION CENTER # 61
Acct. No. 2156 - 45
Permit No. 1121871

Be It Ordained by the City Council of the City of Chicago:

SECTION 1. Permission and authority are hereby given and granted to GENERAL NUTRITION CENTER # 61, upon the terms and subject to the conditions of this ordinance to maintain and use two (2) sign(s) projecting over the public right-of-way attached to its premises known as 5155 S. Pulaski Rd..

Said sign structure(s) measures as follows; along S. Pulaski Road (West Elevation of bldg):
One (1) at twenty-two point eight three (22.83) feet in length, two (2) feet in height and eleven (11) feet above grade level.

Said sign structure(s) measures as follows; along S. Pulaski Road (North Elevation of Bldg):
One (1) at twenty-two point eight three (22.83) feet in length, two (2) feet in height and eleven (11) feet above grade level.

The location of said privilege shall be as shown on prints kept on file with the Department of Business Affairs and Consumer Protection and the Office of the City Clerk.

Said privilege shall be constructed in accordance with plans and specifications approved by the Department of Transportation (Division of Project Development) and Zoning Department - Signs.

This grant of privilege in the public way shall be subject to the provisions of Section 10-28-015 and all other required provisions of the Municipal Code of Chicago.

The grantee shall pay to the City of Chicago as compensation for the privilege #1121871 herein granted the sum of six hundred (\$600.00) per annum in advance.

A 25% penalty will be added for payments received after due date.

The permit holder agrees to hold the City of Chicago harmless for any damage, relocation or replacement costs associated with damage, relocation or removal of private property caused by the City performing work in the public way.

Authority herein given and granted for a period of five (5) years from and after 02/09/2016.

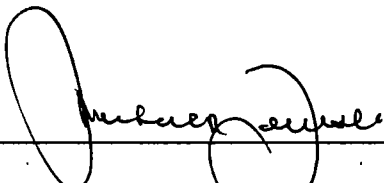
Alderman 
Michael R. Zalewski 23rd Ward

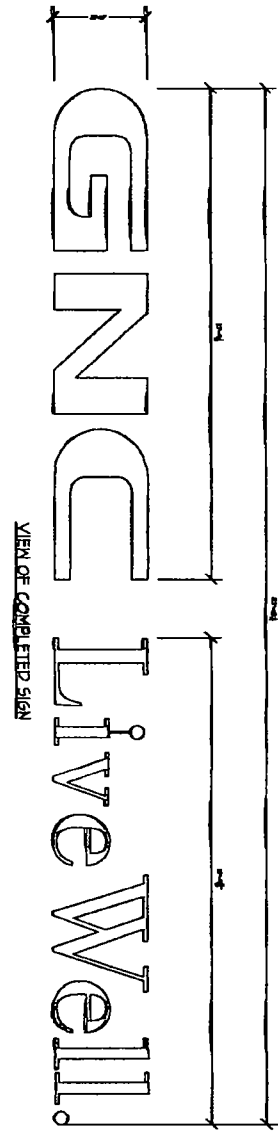

NOTE: UNLESS OTHERWISE SPECIFIED, ALL MATERIALS TO BE USED SHALL BE OF THE HIGHEST QUALITY AVAILABLE. THE CONTRACTOR SHALL BE RESPONSIBLE FOR OBTAINING ALL NECESSARY PERMITS AND APPROVALS FROM THE LOCAL AUTHORITIES. THE CONTRACTOR SHALL BE RESPONSIBLE FOR THE PROTECTION OF ALL EXISTING UTILITIES AND STRUCTURES. THE CONTRACTOR SHALL BE RESPONSIBLE FOR THE PROTECTION OF ALL EXISTING PLANTING AND LANDSCAPING. THE CONTRACTOR SHALL BE RESPONSIBLE FOR THE PROTECTION OF ALL EXISTING HISTORIC STRUCTURES AND MONUMENTS. THE CONTRACTOR SHALL BE RESPONSIBLE FOR THE PROTECTION OF ALL EXISTING CULTURAL RESOURCES. THE CONTRACTOR SHALL BE RESPONSIBLE FOR THE PROTECTION OF ALL EXISTING ARCHAEOLGICAL REMAINS. THE CONTRACTOR SHALL BE RESPONSIBLE FOR THE PROTECTION OF ALL EXISTING ANTHROPOLOGICAL REMAINS. THE CONTRACTOR SHALL BE RESPONSIBLE FOR THE PROTECTION OF ALL EXISTING GEOLOGICAL FORMATIONS. THE CONTRACTOR SHALL BE RESPONSIBLE FOR THE PROTECTION OF ALL EXISTING SOILS AND ROCKS. THE CONTRACTOR SHALL BE RESPONSIBLE FOR THE PROTECTION OF ALL EXISTING VEGETATION AND WILDLIFE. THE CONTRACTOR SHALL BE RESPONSIBLE FOR THE PROTECTION OF ALL EXISTING WATER RESOURCES. THE CONTRACTOR SHALL BE RESPONSIBLE FOR THE PROTECTION OF ALL EXISTING AIR RESOURCES. THE CONTRACTOR SHALL BE RESPONSIBLE FOR THE PROTECTION OF ALL EXISTING CLIMATE RESOURCES. THE CONTRACTOR SHALL BE RESPONSIBLE FOR THE PROTECTION OF ALL EXISTING CULTURAL HERITAGE. THE CONTRACTOR SHALL BE RESPONSIBLE FOR THE PROTECTION OF ALL EXISTING HISTORIC LANDMARKS. THE CONTRACTOR SHALL BE RESPONSIBLE FOR THE PROTECTION OF ALL EXISTING NATIONAL MONUMENTS. THE CONTRACTOR SHALL BE RESPONSIBLE FOR THE PROTECTION OF ALL EXISTING NATIONAL HISTORIC LANDMARKS. THE CONTRACTOR SHALL BE RESPONSIBLE FOR THE PROTECTION OF ALL EXISTING NATIONAL HISTORIC MONUMENTS. THE CONTRACTOR SHALL BE RESPONSIBLE FOR THE PROTECTION OF ALL EXISTING NATIONAL HISTORIC STRUCTURES. THE CONTRACTOR SHALL BE RESPONSIBLE FOR THE PROTECTION OF ALL EXISTING NATIONAL HISTORIC DISTRICTS. THE CONTRACTOR SHALL BE RESPONSIBLE FOR THE PROTECTION OF ALL EXISTING NATIONAL HISTORIC PRESERVATION DISTRICTS. THE CONTRACTOR SHALL BE RESPONSIBLE FOR THE PROTECTION OF ALL EXISTING NATIONAL HISTORIC PRESERVATION MONUMENTS. THE CONTRACTOR SHALL BE RESPONSIBLE FOR THE PROTECTION OF ALL EXISTING NATIONAL HISTORIC PRESERVATION STRUCTURES. THE CONTRACTOR SHALL BE RESPONSIBLE FOR THE PROTECTION OF ALL EXISTING NATIONAL HISTORIC PRESERVATION DISTRICTS. THE CONTRACTOR SHALL BE RESPONSIBLE FOR THE PROTECTION OF ALL EXISTING NATIONAL HISTORIC PRESERVATION MONUMENTS. THE CONTRACTOR SHALL BE RESPONSIBLE FOR THE PROTECTION OF ALL EXISTING NATIONAL HISTORIC PRESERVATION STRUCTURES.

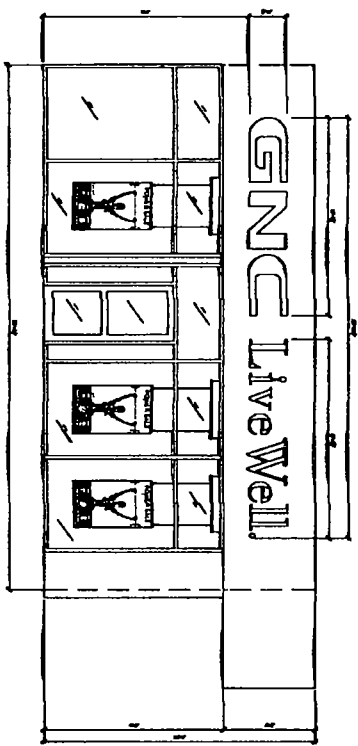

- 1 B/B POLYCARBONATE FACE
- 2 1 TRIM CAP
- 3 GAG ALUMINUM RETURN
- 4 GAG ALUMINUM BRACKS (TOP)
- 5 LED
- 6 LED POWER SUPPLY
- 7 200MA DISCONNECT SWITCH
- 8 3/4" WIRE BROWN CABLE
- 9 3/4" WIRE GREEN TO TRIM CAP
- 10 1/2" BOD
- 11 REBAR WIRING
- 12 D/B PLASTIC BUSHING
- 13 MOUNTING HARDWARE
- 14 GAGS SCHEDULE 40
- 15 FACE RED #3115
- 16 TRIM CAP DARK BRONZE
- 17 METAL LETTER DARK BRONZE
- 18 LED RED
- 19 GAGS SCHEDULE 40
- 20 FACE WHITE #1328
- 21 TRIM CAP PAINT PWS 49 COOL
- 22 METAL LETTER PAINT PWS 49
- 23 LED GRAY
- 24 VINTL OVERLAY ORACAL GRAY
- 25 G/B

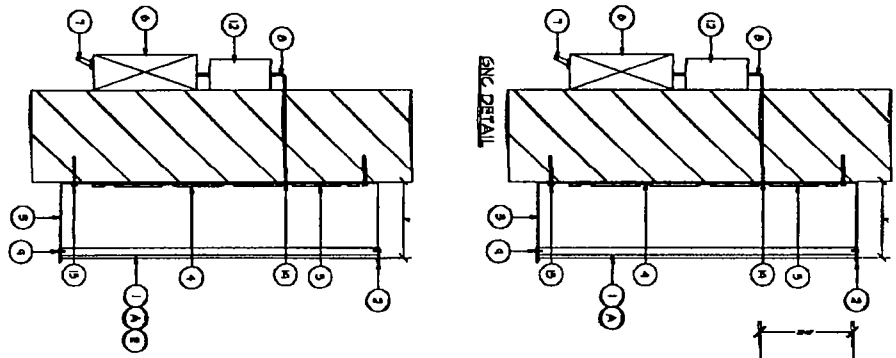

REVISION 15-1200

NOTE: MINIMUM CLEARANCE REQUIRED BEHIND SIGN FROM TOP ELECTRICAL CONNECTIONS

NOTE: Letters are not pre wired and will need to be wired later to allow driving illumination

<p>RSW CONSULTANTS 17211 EAGLE HOLLOW SAN ANTONIO TX 78248 PHONE: 210-498-1860</p>	<p>GNC Live Well.</p> <p>GENERAL MATERIALS CENTER, INC. 310 STATE AVENUE, FORT WORTH, TX 76102 PHONE: 412-338-8517 FAX: 412-338-8576</p>	
	<p>DATE: _____</p> <p>DESCRIPTION: _____</p> <p>REVISIONS: _____</p>	<p>DATE: _____</p> <p>DESCRIPTION: _____</p> <p>REVISIONS: _____</p>



Department of Business Affairs and Consumer Protection
Small Business Center - Public Way Use Unit
City Hall - 121 N. LaSalle Street, Room 800 • Chicago, IL 60602
312-74-GOBIZ / 312-744-6249 • (312) 744-1944 (TTY)
<http://www.cityofchicago.org/bacp>

03/16/2016

Alderman **Michael R. Zalewski**
Ward # 23
City of Chicago
City Hall, Room 200
121 North LaSalle Street
Chicago, Illinois 60602

Re: An ordinance to use and maintain a portion of the public right-of-way for **two (2) sign(s)** for
GENERAL NUTRITION CENTER # 61, adjacent to the premises known as **5155 S. Pulaski Rd.**

Dear Alderman **Michael R. Zalewski**:

The applicant referenced above has requested the use of the public right-of-way for a **sign(s)**. An ordinance has been prepared by the Department of Business Affairs and Consumer Protection – Small Business Center - Public Way Use Unit for presentation to the City Council. Because this request was made for properties located in your ward, as approved by you as per the attached, I respectfully request that you introduce the attached ordinance at the next City Council meeting.

If you have any questions regarding this ordinance, please contact Anthony Bertuca at (312) 744-5506.

Department of Business Affairs and Consumer Protection