



# City of Chicago



O2016-2792

Office of the City Clerk

## Document Tracking Sheet

<b>Meeting Date:</b>	4/13/2016
<b>Sponsor(s):</b>	Moreno (1)
<b>Type:</b>	Ordinance
<b>Title:</b>	Grant(s) of privilege in public way for Baocos
<b>Committee(s) Assignment:</b>	Committee on Transportation and Public Way

ORDINANCE  
BAOCOS  
Acct. No. 396419 - 1  
Permit No. 1117077

*Be It Ordained by the City Council of the City of Chicago:*

SECTION 1. Permission and authority are hereby given and granted to BAOCOS, upon the terms and subject to the conditions of this ordinance to maintain and use two (2) sign(s) projecting over the public right-of-way attached to its premises known as 1904 N. Western Ave..

Said sign structure(s) measures as follows; along N. Western Avenue:

One (1) at twenty-three point six seven (23.67) feet in length, one point six two (1.62) feet in height and fourteen point five (14.5) feet above grade level.

Said sign structure(s) measures as follows; along W. Cortland Street:

One (1) at nineteen point two five (19.25) feet in length, one (1) foot in height and fifteen point five (15.5) feet above grade level.

The location of said privilege shall be as shown on prints kept on file with the Department of Business Affairs and Consumer Protection and the Office of the City Clerk.

Said privilege shall be constructed in accordance with plans and specifications approved by the Department of Transportation (Division of Project Development) and Zoning Department - Signs.

This grant of privilege in the public way shall be subject to the provisions of Section 10-28-015 and all other required provisions of the Municipal Code of Chicago.

The grantee shall pay to the City of Chicago as compensation for the privilege #1117077 herein granted the sum of four hundred (\$400.00) per annum in advance.

A 25% penalty will be added for payments received after due date.

The permit holder agrees to hold the City of Chicago harmless for any damage, relocation or replacement costs associated with damage, relocation or removal of private property caused by the City performing work in the public way.

Authority herein given and granted for a period of five (5) years from and after Date of Passage.

Alderman \_\_\_\_\_



Proco Joe Moreno 1<sup>st</sup> Ward

# SIGN #1

Red Head Anchor

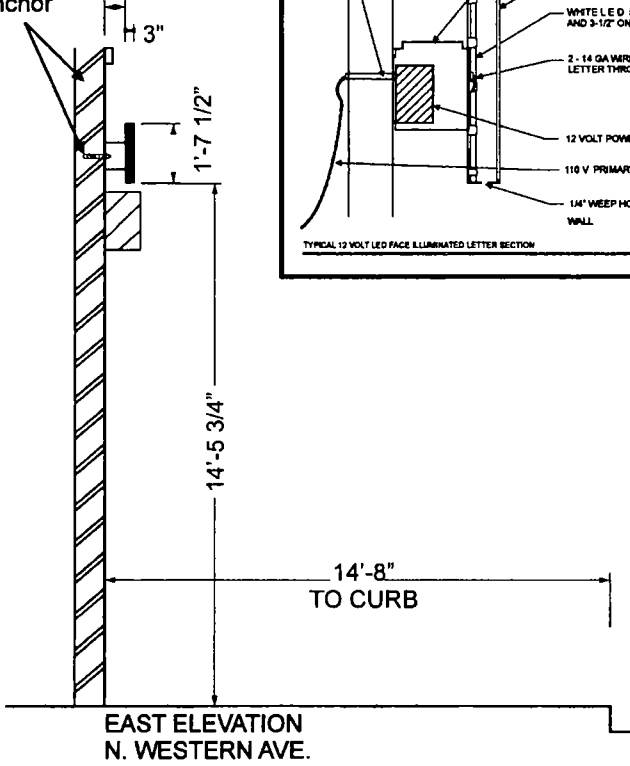

EAST ELEVATION  
N. WESTERN AVE.

## FACE LIT CHANNEL LETTER DETAIL

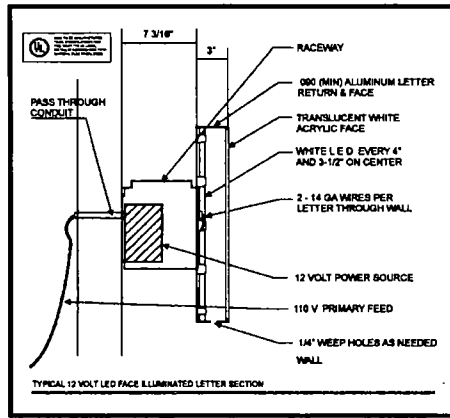

# SIGN #2

Red Head Anchor

*THIS ONE*

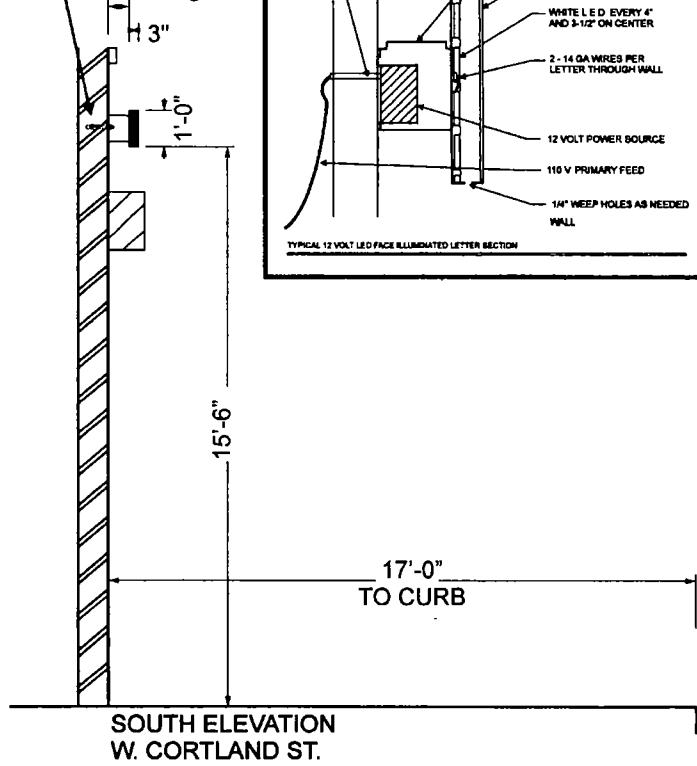

SOUTH ELEVATION  
W. CORTLAND ST.

## FACE LIT CHANNEL LETTER DETAIL

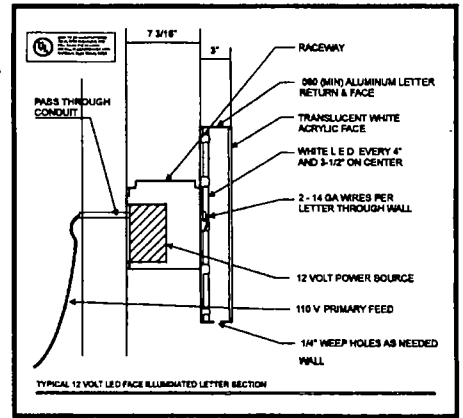

SCALE: 1/2" = 1'-0"

### Chicago Sign Group, llc

305 Albert Drive  
Vernon Hills, IL 60061  
847.899.9021  
www.ChicagoSignGroup.com  
David@ChicagoSignGroup.com

### Customer:

BAOCOS  
ERV EMERY  
1904 N WESTERN AVE  
CHICAGO, IL 60647  
847-417-9139  
erv@baocos.com

### Location:

BAOCOS  
ERV EMERY  
1904 N WESTERN AVE  
CHICAGO, IL 60647  
847-417-9139  
erv@baocos.com

Customer Approval \_\_\_\_\_

Landlord Approval \_\_\_\_\_

© Copyright 2014  
by Chicago Sign  
Group, llc  
All designs presented  
are the sole property  
of Chicago Sign Group,  
llc and may not be  
reproduced in part  
or in whole without  
written permission



04/13/2016

Alderman **Proco Joe Moreno**  
Ward # 01  
City of Chicago  
City Hall, Room 300  
121 North LaSalle Street  
Chicago, Illinois 60602

Re: An ordinance to use and maintain a portion of the public right-of-way for **two (2) sign(s)** for **BAOCOS**, adjacent to the premises known as **1904 N. Western Ave.**.

Dear Alderman **Proco Joe Moreno**:

The applicant referenced above has requested the use of the public right-of-way for a **sign(s)**. An ordinance has been prepared by the Department of Business Affairs and Consumer Protection – Small Business Center - Public Way Use Unit for presentation to the City Council. Because this request was made for properties located in your ward, as approved by you as per the attached, I respectfully request that you introduce the attached ordinance at the next City Council meeting.

If you have any questions regarding this ordinance, please contact Anthony Bertuca at (312) 744-5506.

**Department of Business Affairs and Consumer Protection**