



City of Chicago



O2016-9094

Office of the City Clerk

Document Tracking Sheet

Meeting Date:	12/14/2016
Sponsor(s):	Solis (25)
Type:	Ordinance
Title:	Grant(s) of privilege in public way for Madison Bar + Kitchen, The
Committee(s) Assignment:	Committee on Transportation and Public Way

ORDINANCE
THE MADISON BAR + KITCHEN
Acct. No. 407383 - 1
Permit No. 1125127

Be It Ordained by the City Council of the City of Chicago:

SECTION 1. Permission and authority are hereby given and granted to THE MADISON BAR + KITCHEN, upon the terms and subject to the conditions of this ordinance to construct, install, maintain and use one (1) Wind Screen(s) on the public right-of-way adjacent to its premises known as 1027 W. Madison St..

Said Wind Screen(s) at W Madison St measure(s):

One (1) at five point one seven (5.17) feet in length, and four (4) feet in width for a total of twenty point six eight (20.68) square feet.

The location of said privilege shall be as shown on prints kept on file with the Department of Business Affairs and Consumer Protection and the Office of the City Clerk.

Said privilege shall be constructed in accordance with plans and specifications approved by the Department of Transportation (Division of Project Development).

This grant of privilege in the public way shall be subject to the provisions of Section 10-28-015 and all other required provisions of the Municipal Code of Chicago.

The grantee shall pay to the City of Chicago as compensation for the privilege #1125127 herein granted the sum of four hundred (\$400.00) per annum in advance.

A 25% penalty will be added for payments received after due date.

The permit holder agrees to hold the City of Chicago harmless for any damage, relocation or replacement costs associated with damage, relocation or removal of private property caused by the City performing work in the public way.

Authority herein given and granted for a period of five (5) years from and after Date of Passage.

Alderman _____

Daniel S. Solls 25th Ward

Job # 726660
Madison Bar

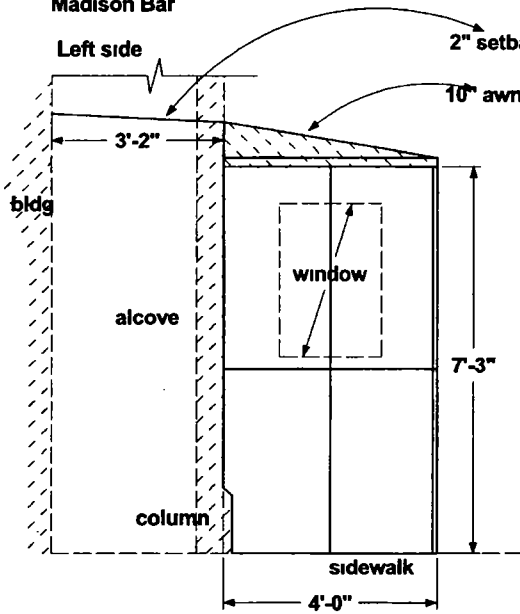

Front view / enclosure

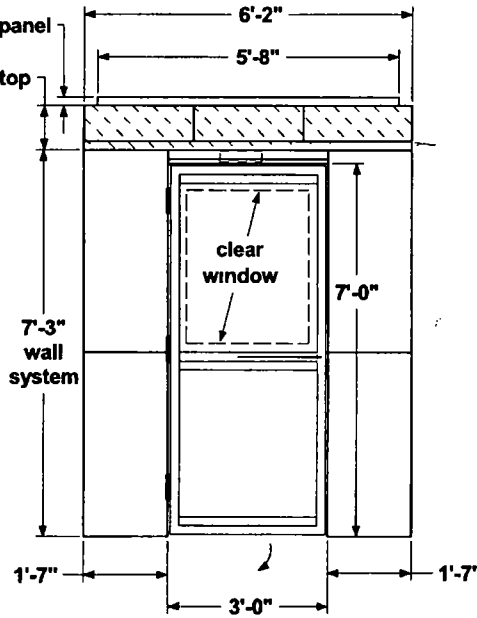

Right side

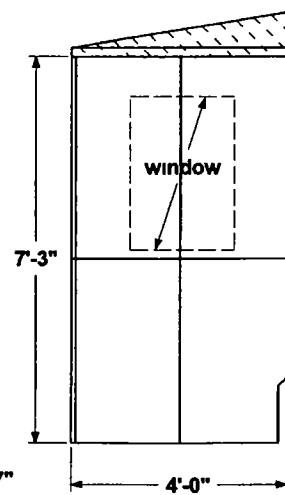

Notes

- alum staple frames (5)
- modular welded, silver frame finish
- 1 door at front
- Sunbrella fabric + clear vinyl



Department of Business Affairs and Consumer Protection

Small Business Center - Public Way Use Unit

City Hall - 121 N. LaSalle Street, Room 800 • Chicago, IL 60602

312-74-GOBIZ / 312-744-6249 • (312) 744-1944 (TTY)

<http://www.cityofchicago.org/bacp>

12/14/2016

Alderman **Daniel S. Solis**

Ward # **25**

City of Chicago

City Hall, Room **304**

121 North LaSalle Street

Chicago, Illinois 60602

Re: An ordinance to use and maintain a portion of the public right-of-way for **one (1) wind screen(s)** for **THE MADISON BAR + KITCHEN**, adjacent to the premises known as **1027 W. Madison St.**.

Dear Alderman **Daniel S. Solis**:

The applicant referenced above has requested the use of the public right-of-way for a **wind screen(s)**. An ordinance has been prepared by the Department of Business Affairs and Consumer Protection – Small Business Center - Public Way Use Unit for presentation to the City Council. Because this request was made for properties located in your ward, as approved by you as per the attached, I respectfully request that you introduce the attached ordinance at the next City Council meeting.

If you have any questions regarding this ordinance, please contact Anthony Bertuca at (312) 744-5506.

Department of Business Affairs and Consumer Protection