



City of Chicago



Or2019-105

Office of the City Clerk

Document Tracking Sheet

Meeting Date:	3/13/2019
Sponsor(s):	Reilly (42)
Type:	Order
Title:	Issuance of permits for sign(s)/signboard(s) at 303 E Superior St
Committee(s) Assignment:	Committee on Zoning, Landmarks and Building Standards

CITY COUNCIL
COMMITTEE ON ZONING, LANDMARKS AND BUILDING STANDARDS

COUNCIL ORDER

RE: Approval of sign over 100 square feet in area or over 24 feet above grade

ORDERED, that the City Council hereby approves the following sign application submitted by:

Applicant*: NORTHWESTERN UNIVERSITY

(* The Applicant is the owner of the real property or the business tenant of the real property. Do not list the sign contractor, sign erector, sign company or advertising entity in the above space.)

This Order approves the following sign in accordance with Municipal Code of Chicago Section 13-20-680:

Address of Sign: 303 E SUPERIOR ST Chicago, IL 60611

Zoning District: PD-3

DOB Sign Permit Application #: 100803847

Sign Details:

1. On-premise OR Off-premise

2. Static sign OR Dynamic-image display sign

3. Number of sign faces 1

4. Projecting over the public way N (Yes or No) If yes, Public Way Use #: _____

5. Dimensions: Length 26 feet 7 inches Height 8 feet 4 inches

Total square feet in area: 222 feet _____ inches

6. Height above grade: 14 feet 0 inches

7. Elevation (side of building or lot where the sign will be erected): NORTH

8. Name of Sign Contractor/Erector: POBLOCKI SIGN COMPANY

To be legal, such sign shall comply with all provisions of Title 17 of the Chicago Municipal Code ("Zoning Ordinance") and all other provisions of the Municipal Code governing the permitting, construction and maintenance and removal of signs and sign structures. Failure of the applicant and the applicant's successors to comply shall be grounds for invalidation or revocation of the sign permit.

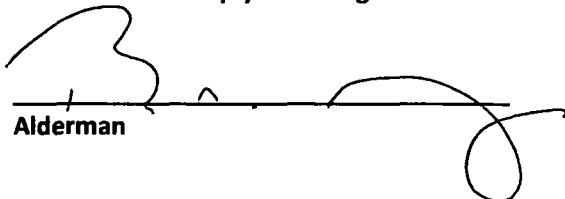
Alderman

Ward

SIGN SPECIFICATIONS

[A] - NON-ILLUMINATED LETTERS

- Description: Fabricated with full backs
- Depth: 1"
- Material: Stainless Steel (316 Alloy)
- Finish: Brushed and Finish (Setin 100 Grit) with horizontal grain
- Installation: Flush w/ VHB tape
- Font: Akkurat Bold

[B] - VINYL BACKER (NOT SHOWN)

- Color: 7723-31 Medium Gray
- Installation: Apply to glass (Second Surface)

INSTALLATION DETAIL
Exterior Application

1. Cut VHB tape to size
2. Clean substrate with 90% alcohol
3. Apply VHB tape to substrate
4. Apply sign to VHB tape
5. Press sign to substrate
6. Trim excess VHB tape
7. Clean sign and substrate with 90% alcohol

Installation Precautions:

1. Clean substrate with 90% alcohol
2. Press sign to substrate with roller
3. Trim excess VHB tape
4. Clean sign and substrate with 90% alcohol

NO GLASS CLEANERS ALLOWED!

1. Apply to glass (Second Surface)

Please refer to "VHB Tape Standard" for complete instructions and Primer Table.

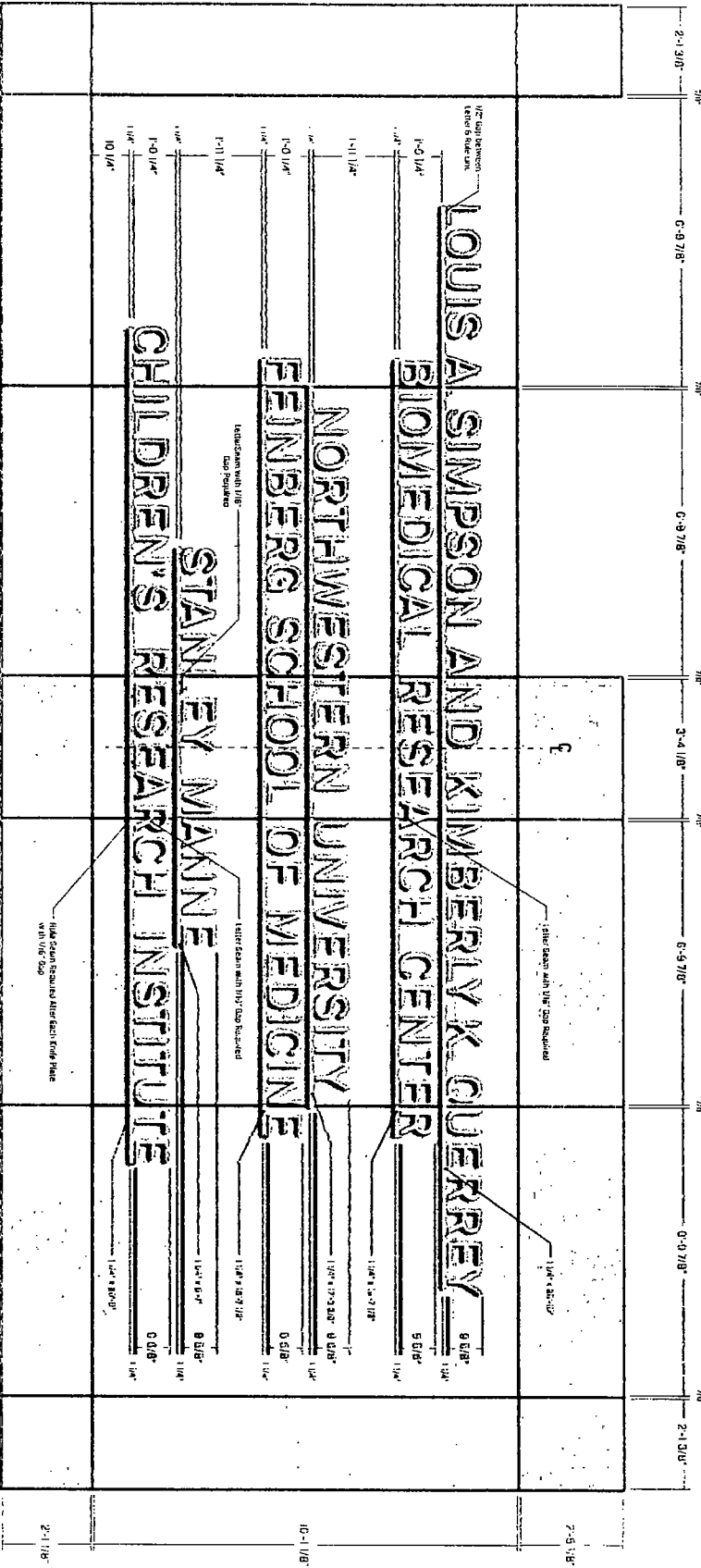

Chicago, Illinois

Northwestern
Biomedical Research
Center

Chicago, Illinois

Chicago, Illinois

Scale: 3/8" = 1'

General Notes: See 10/11/10

Notes:

Revisions:
DATE: REVISIONS: BY: DATE:

Site: General
Author: James Anderson
Sign 100, Np. *

E03

NI Building ID

Sign Size

83191

user - Biomed - KRM/NA

101

10/11/10

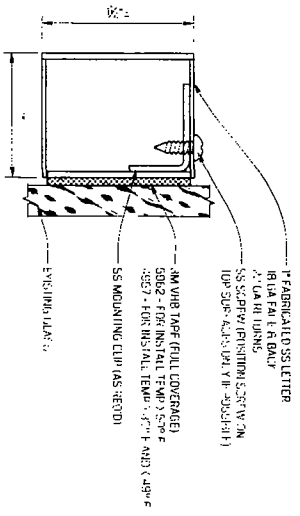

TYPICAL SECTION
SCALE: 1/2" = 1'-0"

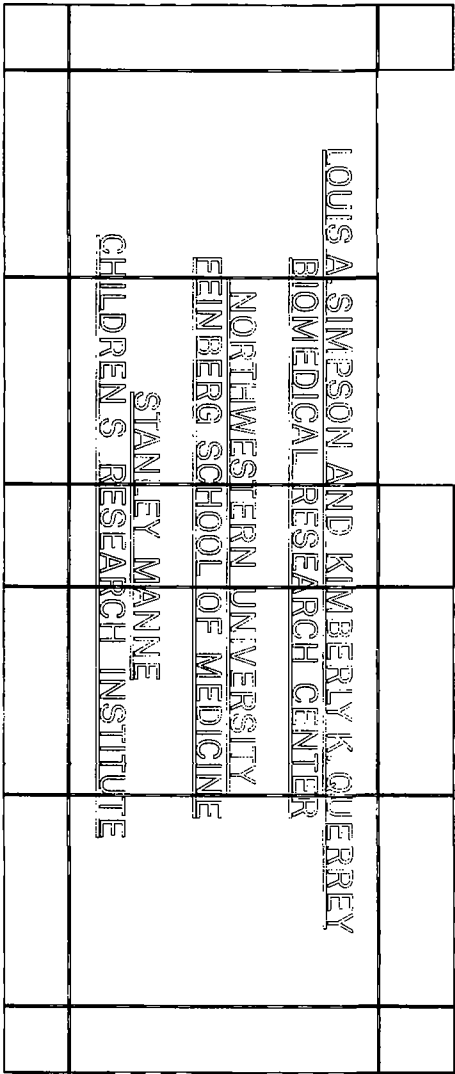

FRONT ELEVATION
SCALE: 1/4" = 1'-0"

WIRE TAPE (PENDING SPECIFICATION)
IGUA PANEL (PENDING SPECIFICATION)
1" FABRICATED GLASS
10P SCREW (PENDING SPECIFICATION)
1/2" WIRE TAPE (FULL COVERAGE)
5002 - FOR INSTALL TEMP. 50°F
5057 - FOR INSTALL TEMP. 50°F AND 49°F
SS MOUNTING CLIP (AS REQ'D)

** FABRICATION NOTE **
UNLESS APPROVED BY ENGINEERING
ALL LETTERS TO HAVE FULL BACKS
WITH FULL TAPE COVERAGE

- REVISIONS:
1. REVISION 1: ADD THE 1/2" BELLOW ON THE WIRE TAPE
 2. REVISION 2: ADD THE 1/2" BELLOW ON THE WIRE TAPE
 3. REVISION 3: ADD THE 1/2" BELLOW ON THE WIRE TAPE
 4. REVISION 4: ADD THE 1/2" BELLOW ON THE WIRE TAPE
 5. REVISION 5: ADD THE 1/2" BELLOW ON THE WIRE TAPE
 6. REVISION 6: ADD THE 1/2" BELLOW ON THE WIRE TAPE
 7. REVISION 7: ADD THE 1/2" BELLOW ON THE WIRE TAPE
 8. REVISION 8: ADD THE 1/2" BELLOW ON THE WIRE TAPE
 9. REVISION 9: ADD THE 1/2" BELLOW ON THE WIRE TAPE
 10. REVISION 10: ADD THE 1/2" BELLOW ON THE WIRE TAPE

MATERIAL	SURFACE PREP		CLEANING	SHOP PRIMERS		FIELD PRIMERS	
	ABRASION	SEALANT		50/50 IP/WATER	PRIMER 94	AP 115	PRIMER 94
ALUMINUM	AS REQ'D		X	0		X	
BRASS		VARNISH/LACQUER	X	0		0	
BRICK		PAINT/CONCRETE SEALER	X	0		X	
BRONZE		VARNISH/LACQUER	X	0		0	
CERAMIC TILE		PAINT/CONCRETE SEALER	X	0		ALT	X
CONCRETE		VARNISH	X	0		X	
COPPER		VARNISH	X	0		0	
GLASS		VARNISH/LACQUER	X	ALT	X	ALT	X
MUNTZ		VARNISH/LACQUER	X	0		0	
PAINT	AS REQ'D		X	0		X	
PLASTIC	AS REQ'D		X	0		X	
STEEL	AS REQ'D		X	0		X	
STONE		VARNISH	X	ALT	X	ALT	X
WOOD					SEE ENGINEERING		
FROSTED GLASS					SEE ENGINEERING		
VINYL					SEE ENGINEERING		
PVC					SEE ENGINEERING		

X = REQUIRED, 0 = OPTIONAL, ALT = ALTERNATE PRIMER **NO GLASS CLEANERS ALLOWED**

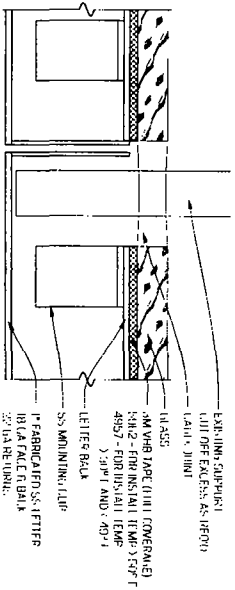

BAR PLAN VIEW
AT CAULK JOINT
SCALE: 1/2" = 1'-0"

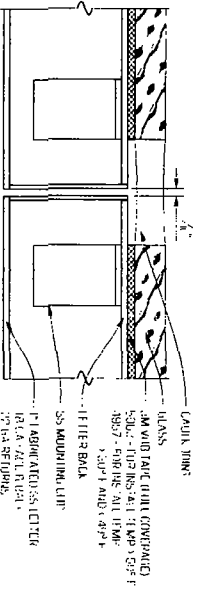

LETTER PLAN VIEW
AT CAULK JOINT
SCALE: 1/2" = 1'-0"



1000 North Western Ave.
Chicago, IL 60610
Tel: 312.329.3300
Fax: 312.329.3301
www.pdblocki.com

Project:
NORTHWESTERN
BIOMEDICAL RESEARCH
CENTER
CHICAGO, IL

Scale: AS NOTED
Date: 11/11/09
Notes:

Revisions

REV: 08/27/09-010	BY: [Signature]
1. PROJECT CHANGES	DATE: 08/27/09
2. LETTER SET	DATE: 11/11/09

Sign Loc. No. E03
Sign Type: KERN-LIN LETTER
Date: 12/1/09
By: WADE CARTER

83191 S01

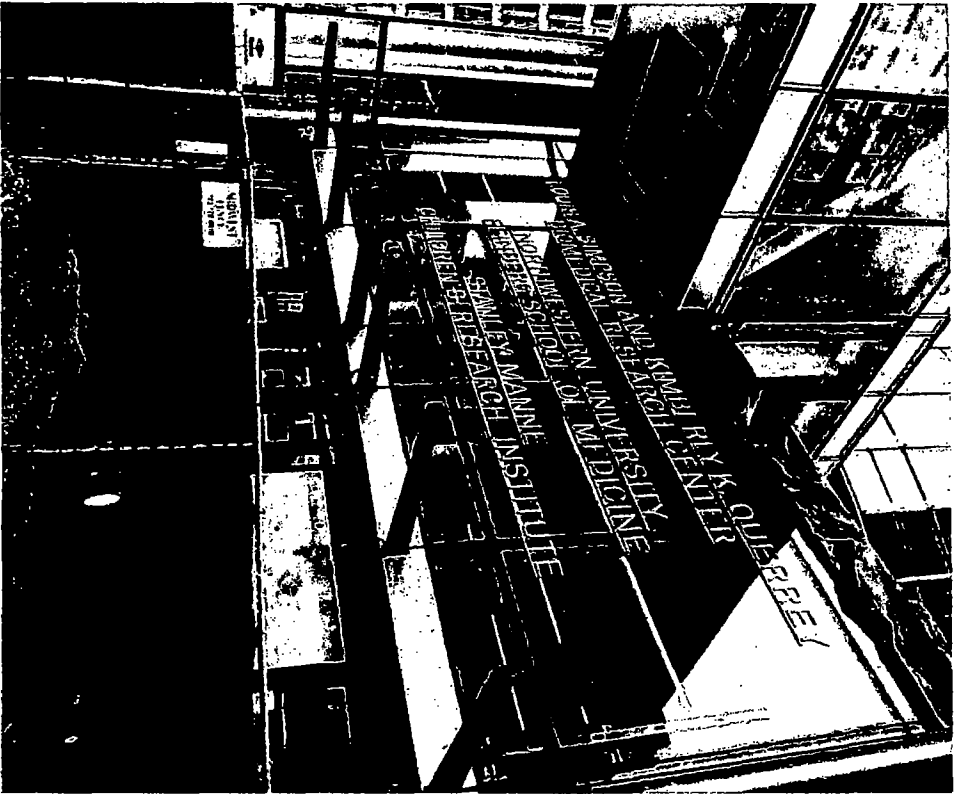

Proposed Day-Light Rendering



Proposed Night Rendering

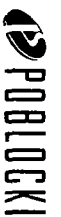

Architectural Firm

1000 North Dearborn Street, Suite 1000
Chicago, Illinois 60610
Tel: 312.462.1000
Fax: 312.462.1001
www.pblocki.com

Project

**Northwestern
Biomedical Research
Center**

Chicago, Illinois

Scale: NTS

International: 100' x 100'

Notes

NOVEMBER 2007

1000 North Dearborn Street, Suite 1000
Chicago, Illinois 60610
Tel: 312.462.1000
Fax: 312.462.1001
www.pblocki.com

Sheet No. *

E03-PH

Photo Edit of NE Building ID

Scale: As Shown

83191

J01

1000 North Dearborn Street, Suite 1000
Chicago, Illinois 60610
Tel: 312.462.1000
Fax: 312.462.1001
www.pblocki.com