



City of Chicago



O2019-8747

Office of the City Clerk

Document Tracking Sheet

Meeting Date: 11/13/2019
Sponsor(s): Reilly (42)
Type: Ordinance
Title: Grant(s) of privilege in public way for NWC 308 W Erie LLC
Committee(s) Assignment: Committee on Transportation and Public Way

ORDINANCE
NWC 308 W ERIE LLC
Acct. No. 463514 - 1
Permit No. 1142617

Be It Ordained by the City Council of the City of Chicago:

SECTION 1. Permission and authority are hereby given and granted to NWC 308 W ERIE LLC, upon the terms and subject to the conditions of this ordinance to construct, install, maintain and use one (1) Door Swing(s) on the public right-of-way adjacent to its premises known as 308 W. Erie St..

Said Door Swing(s) at W. Erie Street measure(s):

One (1) at three (3) feet in length, and one point five eight (1.58) foot in width for a total of four point seven four (4.74) square feet.

The location of said privilege shall be as shown on prints kept on file with the Department of Business Affairs and Consumer Protection and the Office of the City Clerk.

Said privilege shall be constructed in accordance with plans and specifications approved by the Department of Transportation (Division of Project Development).

This grant of privilege in the public way shall be subject to the provisions of Section 10-28-015 and all other required provisions of the Municipal Code of Chicago.

The grantee shall pay to the City of Chicago as compensation for the privilege #1142617 herein granted the sum of seventy-five (\$75.00) per annum in advance.

A 25% penalty will be added for payments received after due date.

The permit holder agrees to hold the City of Chicago harmless for any damage, relocation or replacement costs associated with damage, relocation or removal of private property caused by the City performing work in the public way.

Authority herein given and granted for a period of five (5) years from and after Date of Passage.

Alderman

Brendan Reilly 42nd Ward

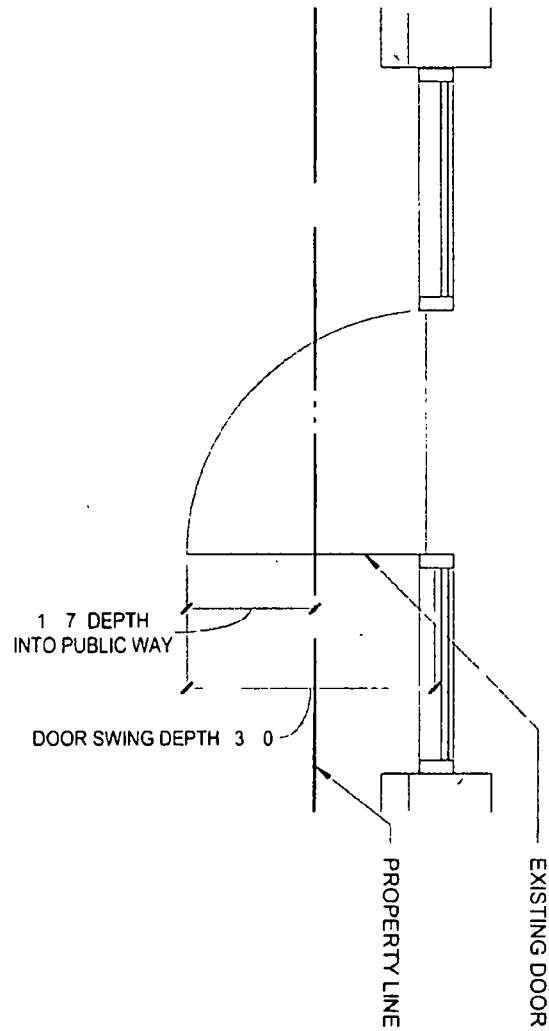

NORR
ARCHITECTS PLANNERS
325 N LaSalle St Suite 500 Chicago IL 60654
T 312 424 2400 F 312 424 2424 www.norr.com

PROJECT NCCA19.0031
308 W ERIE ST
308 W ERIE
CHICAGO IL 60654

STAIR DOOR PLAN
SK-03
08/20/19