



City of Chicago



O2019-8824

Office of the City Clerk

Document Tracking Sheet

Meeting Date:	11/13/2019
Sponsor(s):	Burnett (27)
Type:	Ordinance
Title:	Grant(s) of privilege in public way for River North Devco LLC - caissons
Committee(s) Assignment:	Committee on Transportation and Public Way

ORDINANCE
RIVER NORTH DEVCO, LLC
Acct. No. 364577 - 2
Permit No. 1142183

Be It Ordained by the City Council of the City of Chicago:

SECTION 1. Permission and authority are hereby given and granted to RIVER NORTH DEVCO, LLC, upon the terms and subject to the conditions of this ordinance to construct, install, maintain and use four (4) Caisson(s) under the public right-of-way adjacent to its premises known as 808 N. Wells St..

Said Caisson(s) at W CHICAGO AVE measure(s):

Two (2) at four (4) feet in length, and two (2) feet in width for a total of sixteen (16) square feet.

Said Caisson(s) at WEST SIDE OF PROPERTY measure(s):

Two (2) at four (4) feet in length, and two (2) feet in width for a total of sixteen (16) square feet.

The location of said privilege shall be as shown on prints kept on file with the Department of Business Affairs and Consumer Protection and the Office of the City Clerk.

Said privilege shall be constructed in accordance with plans and specifications approved by the Department of Planning and Development and Department of Transportation (Office of Underground Coordination).

This grant of privilege in the public way shall be subject to the provisions of Section 10-28-015 and all other required provisions of the Municipal Code of Chicago.

The grantee shall pay to the City of Chicago as compensation for the privilege #1142183 herein granted the sum of four hundred (\$400.00) per annum in advance.

A 25% penalty will be added for payments received after due date.

The permit holder agrees to hold the City of Chicago harmless for any damage, relocation or replacement costs associated with damage, relocation or removal of private property caused by the City performing work in the public way.

Authority herein given and granted for a period of five (5) years from and after Date of Passage.

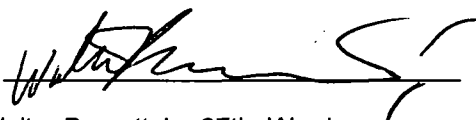
Alderman 
Walter Burnett Jr. 27th Ward

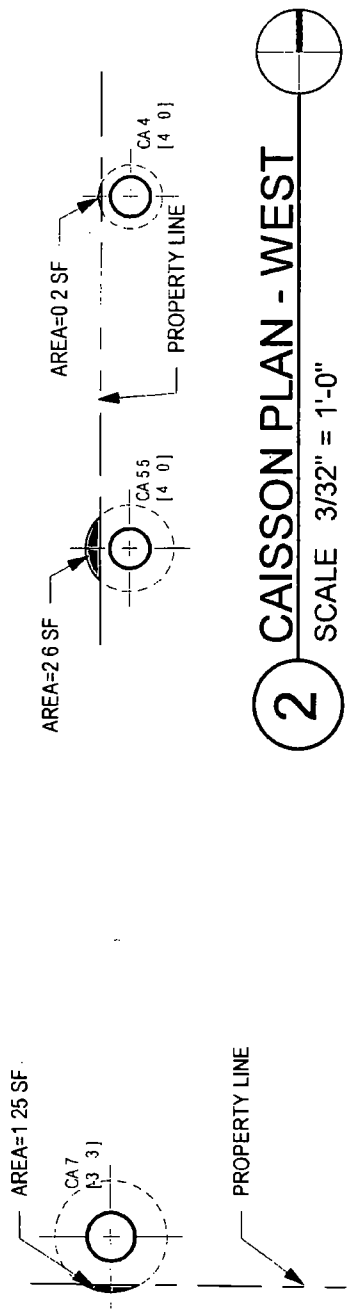

2 CAISSON PLAN - WEST
SCALE 3/32" = 1'-0"

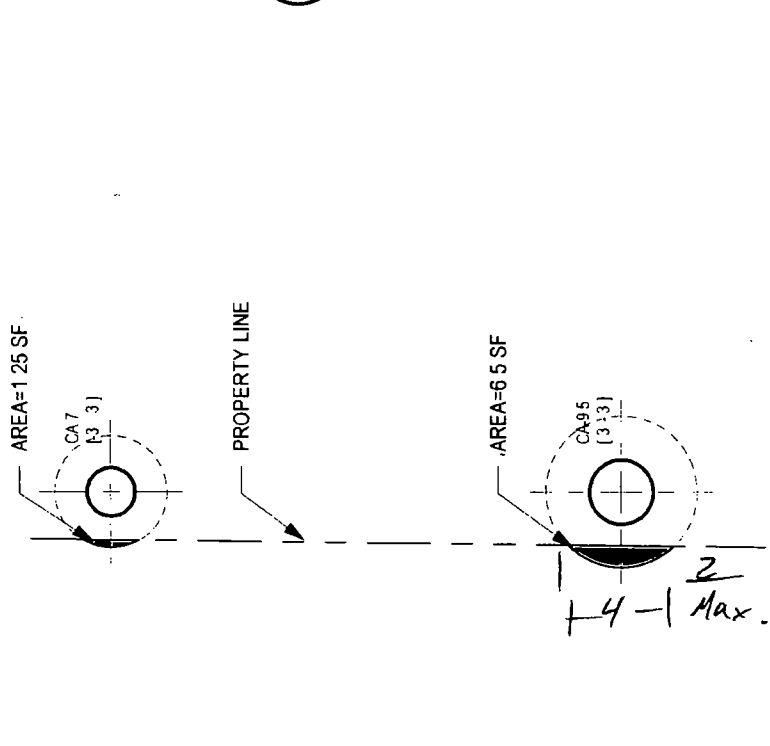

1 CAISSON PLAN - SOUTH
SCALE 3/32" = 1'-0"

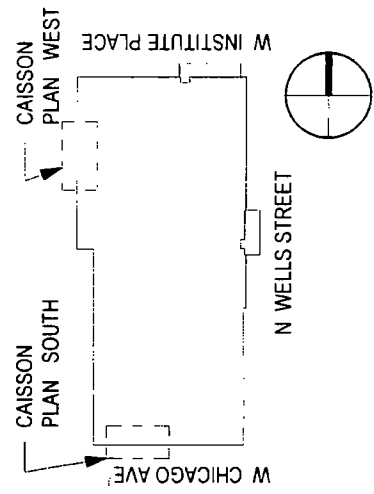

GRANT OF PRIVILEGE - 03

CAISSONS

NICH19.02/16.00

PROJECT: 08/27/19

AMLI 808

808 N WELLS ST CHICAGO IL 60610

NORR PLANNERS ARCHITECTS

325 N LaSalle St. Suite 500 Chicago IL 60654
t 312.424.7400 f 312.424.2424 www.norr.com