



City of Chicago



O2020-2004

Office of the City Clerk Document Tracking Sheet

Meeting Date:	4/22/2020
Sponsor(s):	Waguespack (32)
Type:	Ordinance
Title:	Awning(s) for Golden Apple Restaurant
Committee(s) Assignment:	Committee on Transportation and Public Way

ORDINANCE
GOLDEN APPLE RESTAURANT
Acct. No. 4488 - 1
Permit No. 1144263

Be It Ordained by the City Council of the City of Chicago:

SECTION 1. Permission and authority are hereby given and granted to GOLDEN APPLE RESTAURANT, upon the terms and subject to the conditions of this ordinance to maintain and use, as now constructed, three (3) Awning(s) projecting over the public right-of-way adjacent to its premises known as 2971 N. Lincoln Ave..

Said Awning(s) at N. Lincoln Avenue measure(s):

One (1) at eighty-two (82) feet in length, and two (2) feet in width for a total of one hundred sixty-four (164) square feet.

One (1) at five (5) feet in length, and two (2) feet in width for a total of ten (10) square feet.

Said Awning(s) at Wellington measure(s):

One (1) at sixty-six (66) feet in length, and two (2) feet in width for a total of one hundred thirty-two (132) square feet.

The location of said privilege shall be as shown on prints kept on file with the Department of Business Affairs and Consumer Protection and the Office of the City Clerk.

Said privilege shall be constructed in accordance with plans and specifications approved by the Zoning Department - Signs.

This grant of privilege in the public way shall be subject to the provisions of Section 10-28-015 and all other required provisions of the Municipal Code of Chicago.

The grantee shall pay to the City of Chicago as compensation for the privilege #1144263 herein granted the sum of one hundred seventy-five (\$175.00) per annum in advance.

A 25% penalty will be added for payments received after due date.

The permit holder agrees to hold the City of Chicago harmless for any damage, relocation or replacement costs associated with damage, relocation or removal of private property caused by the City performing work in the public way.

Authority herein given and granted for a period of five (5) years from and after 03/23/2020.

Alderman _____

Scott Waguespack 32nd Ward

Golden Apple Restaurant
2971 N Lincoln

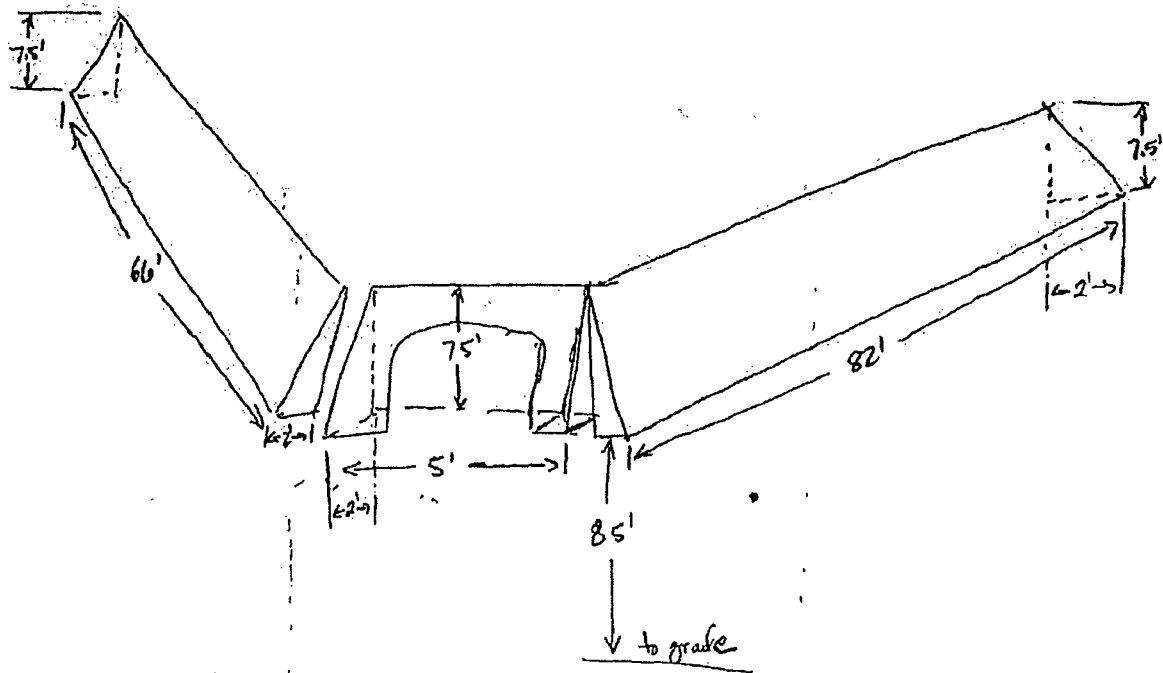



Department of Business Affairs and Consumer Protection
Small Business Center- Public Way Use Unit
City Hall - 121 N. LaSalle Street, Room 800 • Chicago, IL 60602
312-74-GOBIZ / 312-744-6249 • (312) 744-1944 (TTY)
<http://www.cityofchicago.org/bacp>

03/18/2020

Alderman Scott Waguespack
Ward # 32
City of Chicago
City Hall, Room 300
121 North LaSalle Street
Chicago, Illinois 60602

Re: An ordinance to use and maintain a portion of the public right-of-way for **three (3) awning(s)** for **GOLDEN APPLE RESTAURANT**, adjacent to the premises known as **2971 N. Lincoln Ave.**.

Dear Alderman Scott Waguespack:

The applicant referenced above has requested the use of the public right-of-way for a **awning(s)**. An ordinance has been prepared by the Department of Business Affairs and Consumer Protection – Small Business Center - Public Way Use Unit for presentation to the City Council. Because this request was made for properties located in your ward, as approved by you as per the attached, I respectfully request that you introduce the attached ordinance at the next City Council meeting.

If you have any questions regarding this ordinance, please contact Anthony Bertuca at (312) 744-5506.

Department of Business Affairs and Consumer Protection