



# City of Chicago



O2020-2019

## Office of the City Clerk Document Tracking Sheet

<b>Meeting Date:</b>	4/22/2020
<b>Sponsor(s):</b>	Waguespack (32)
<b>Type:</b>	Ordinance
<b>Title:</b>	Grant(s) of privilege in public way for Mi Nueva Tierra
<b>Committee(s) Assignment:</b>	Committee on Transportation and Public Way

ORDINANCE  
MI NUEVA TIERRA  
Acct. No. 464798 - 1  
Permit No. 1144711

*Be It Ordained by the City Council of the City of Chicago:*

SECTION 1. Permission and authority are hereby given and granted to MI NUEVA TIERRA, upon the terms and subject to the conditions of this ordinance to maintain and use one (1) sign(s) projecting over the public right-of-way attached to its premises known as 2417 N. Clybourn Ave..

Said sign structure(s) measures as follows; along N CLYBOURN AVE:

One (1) at eleven point three three (11.33) feet in length, two point seven five (2.75) feet in height and ten (10) feet above grade level.

The location of said privilege shall be as shown on prints kept on file with the Department of Business Affairs and Consumer Protection and the Office of the City Clerk.

Said privilege shall be constructed in accordance with plans and specifications approved by the Department of Transportation (Division of Project Development) and Zoning Department - Signs.

This grant of privilege in the public way shall be subject to the provisions of Section 10-28-015 and all other required provisions of the Municipal Code of Chicago.

The grantee shall pay to the City of Chicago as compensation for the privilege #1144711 herein granted the sum of three hundred (\$300.00) per annum in advance.

A 25% penalty will be added for payments received after due date.

The permit holder agrees to hold the City of Chicago harmless for any damage, relocation or replacement costs associated with damage, relocation or removal of private property caused by the City performing work in the public way.

Authority herein given and granted for a period of five (5) years from and after Date of Passage.

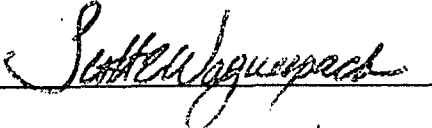
Alderman   
Scott Waguespack 32<sup>nd</sup> Ward

Mi Nueva Tierra • 2417 N Clybourn Ave • Chicago • IL



A Front-Lit, Plex-Face Channel Letters w/ LED, Raceway Mounted • Front View

INTERNALLY ILLUMINATED PLASTIC FACE CHANNEL LETTERS

<b>QUANTITY</b>	ONE (1)
<b>Overall Height</b>	2' 9"
<b>Overall Length</b>	11'-4"
<b>Total Sq Ft</b>	31.15 sq ft
<b>① Returns</b>	Black COLOR
<b>② Backs</b>	060 Aluminum
<b>③ Trimcap</b>	#2025 Black
<b>④ Face</b>	#2037 Yellow
<b>⑤ Raceway</b>	Black
<b>Illumination</b>	LED Color

**TAGLINE (Cantina Cocina)**  
 Returns Black COLOR  
 Backs 060 Aluminum  
 Trimcap #2025 Black  
 Face #7328 White  
 First surface translucent vinyl  
 3M™ Scotchcal Translucent Graphic Film 3630-43 Light Tomato Red

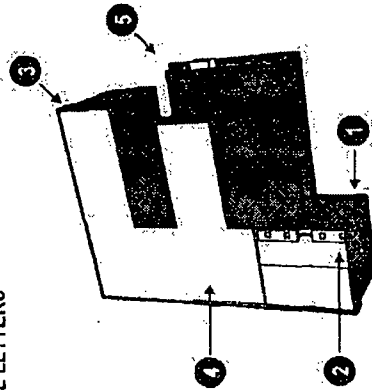

**NOTES**

- WHITE interiors for increased illumination.
- All paint two stage automotive acrylic

**CHANNEL LETTER - TYPICAL SECTION - FRONT-LIT, PLASTIC FACE**

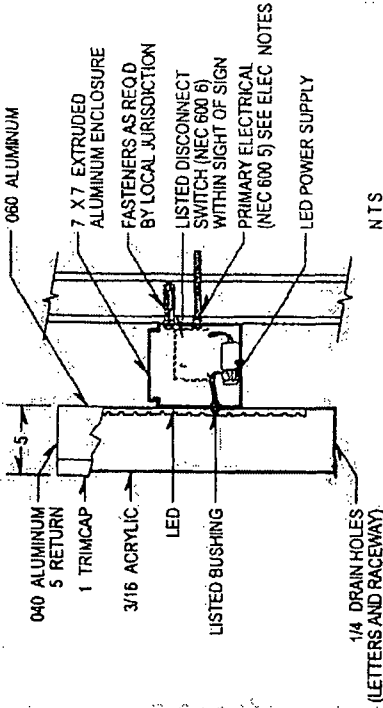

**ELECTRICAL NOTES**

Sign Company DOES NOT provide primary electrical to sign. Power to the sign must be done by a licensed electrical contractor or licensed electrician. Each sign must have: 1. A junction box dedicated to the sign. 2. Junction box installed within 6 feet of sign. 3. Three wires: Line, Ground, Neutral.

**PLEASE REVIEW DRAWINGS FOR ACCURACY IN COLOR LAYOUT. SPELLING APPROVAL STATES ALL CONTENT REPRESENTED IN THIS PROOF IS CORRECT**

5500 N. Kedzie Ave Chicago, IL 60625  
 773-267-6007 | sales@nbsigns.com

**Client Name:** Luis Munez / Juan A. Quiroz  
**Location:** 2417 N. Clybourn Ave. Chicago, IL

**Start Date:** 02/04/2020  
**Last Revision:** 00/00/0000  
**Drawing:** 00/00/00 1.1.1.1  
**Page:** 2 of 3

**Sales Rep:** Seung Park  
**Designer:** Ernesto Guevara

Client Approval  
 Landlord Approval



Department of Business Affairs and Consumer Protection  
Small Business Center - Public Way Use Unit  
City Hall - 121 N. LaSalle Street, Room 800 • Chicago, IL 60602  
312-74-GOBIZ / 312-744-6249 • (312) 744-1944 (TTY)  
<http://www.cityofchicago.org/bacp>

**04/22/2020**

**Alderman Scott Waguespack**  
Ward # 32  
City of Chicago  
City Hall, Room 300  
121 North LaSalle Street  
Chicago, Illinois 60602

Re: An ordinance to use and maintain a portion of the public right-of-way for **one (1) sign(s)** for **MI NUEVA TIERRA**, adjacent to the premises known as **2417 N. Clybourn Ave.**.

Dear **Alderman Scott Waguespack**:

The applicant referenced above has requested the use of the public right-of-way for a **sign(s)**. An ordinance has been prepared by the Department of Business Affairs and Consumer Protection – Small Business Center - Public Way Use Unit for presentation to the City Council. Because this request was made for properties located in your ward, as approved by you as per the attached, I respectfully request that you introduce the attached ordinance at the next City Council meeting.

If you have any questions regarding this ordinance, please contact Anthony Bertuca at (312) 744-5506.

**Department of Business Affairs and Consumer Protection**