



# City of Chicago



O2020-3716

Office of the City Clerk

## Document Tracking Sheet

<b>Meeting Date:</b>	7/22/2020
<b>Sponsor(s):</b>	Burke (14)
<b>Type:</b>	Ordinance
<b>Title:</b>	Grant(s) of privilege in public way for PNC Bank
<b>Committee(s) Assignment:</b>	Committee on Transportation and Public Way

ORDINANCE  
PNC BANK  
Acct. No. 349591 - 10  
Permit No. 1145115

*Be It Ordained by the City Council of the City of Chicago:*

SECTION 1. Permission and authority are hereby given and granted to PNC BANK, upon the terms and subject to the conditions of this ordinance to maintain and use one (1) sign(s) projecting over the public right-of-way attached to its premises known as 5075 S. Archer Ave..

Said sign structure(s) measures as follows; along S Archer Avenue:  
One (1) at ten point four two (10.42) feet in length, three (3) feet in height and thirteen point five (13.5) feet above grade level.

The location of said privilege shall be as shown on prints kept on file with the Department of Business Affairs and Consumer Protection and the Office of the City Clerk.

Said privilege shall be constructed in accordance with plans and specifications approved by the Department of Transportation (Division of Project Development) and Zoning Department - Signs.

This grant of privilege in the public way shall be subject to the provisions of Section 10-28-015 and all other required provisions of the Municipal Code of Chicago.

The grantee shall pay to the City of Chicago as compensation for the privilege #1145115 herein granted the sum of three hundred (\$300.00) per annum in advance.

A 25% penalty will be added for payments received after due date.

The permit holder agrees to hold the City of Chicago harmless for any damage, relocation or replacement costs associated with damage, relocation or removal of private property caused by the City performing work in the public way.

Authority herein given and granted for a period of five (5) years from and after 03/10/2020.

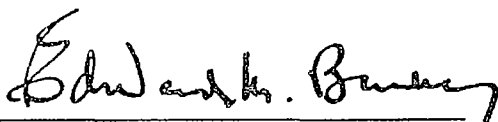
Alderman 

Edward M. Burke 14<sup>th</sup> Ward

Exterior Plan

Site Number 005584

Archer Office  
5075 South Archer Avenue  
Chicago, IL 60632

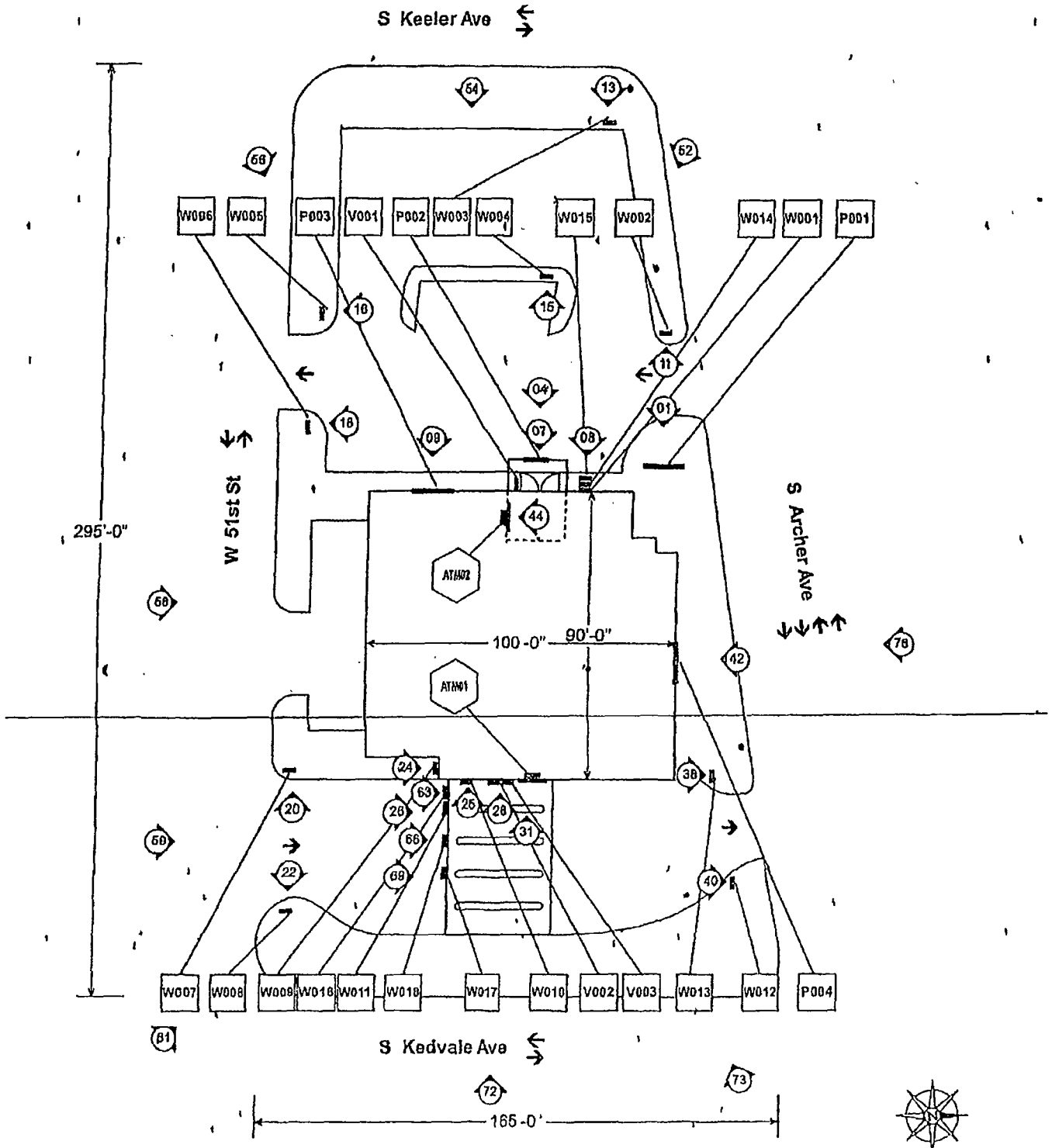



Department of Business Affairs and Consumer Protection  
Small Business Center - Public Way Use Unit  
City Hall - 121 N. LaSalle Street, Room 800 • Chicago, IL 60602  
312-74-GOBIZ / 312-744-6249 • (312) 744-1944 (TTY)  
<http://www.cityofchicago.org/bacp>

07/22/2020

Alderman Edward M. Burke  
Ward # 14  
City of Chicago  
City Hall, Room 302  
121 North LaSalle Street  
Chicago, Illinois 60602

Re: An ordinance to use and maintain a portion of the public right-of-way for **one (1) sign(s)** for PNC BANK, adjacent to the premises known as **5075 S. Archer Ave.**

Dear Alderman Edward M. Burke:

The applicant referenced above has requested the use of the public right-of-way for a **sign(s)**. An ordinance has been prepared by the Department of Business Affairs and Consumer Protection – Small Business Center - Public Way Use Unit for presentation to the City Council. Because this request was made for properties located in your ward, as approved by you as per the attached, I respectfully request that you introduce the attached ordinance at the next City Council meeting.

If you have any questions regarding this ordinance, please contact Anthony Bertuca at (312) 744-5506.

Department of Business Affairs and Consumer Protection