



City of Chicago



O2020-4608

Office of the City Clerk

Document Tracking Sheet

Meeting Date:	10/1/2020
Sponsor(s):	La Spata (1)
Type:	Ordinance
Title:	Grant(s) of privilege in public way for Pot Pan Restaurant
Committee(s) Assignment:	Committee on Transportation and Public Way

Direct Intro
#1

ORDINANCE
POT PAN RESTAURANT
Acct. No. 317468 - 1
Permit No. 1141825

Be It Ordained by the City Council of the City of Chicago:

SECTION 1. Permission and authority are hereby given and granted to POT PAN RESTAURANT, upon the terms and subject to the conditions of this ordinance to maintain and use one (1) sign(s) projecting over the public right-of-way attached to its premises known as 1362 N. Milwaukee Ave..

Said sign structure(s) measures as follows; along N MILWAUKEE AVE:
One (1) at three (3) feet in length, three (3) feet in height and twelve (12) feet above grade level.

The location of said privilege shall be as shown on prints kept on file with the Department of Business Affairs and Consumer Protection and the Office of the City Clerk.

Said privilege shall be constructed in accordance with plans and specifications approved by the Department of Transportation (Division of Project Development) and Zoning Department - Signs.

This grant of privilege in the public way shall be subject to the provisions of Section 10-28-015 and all other required provisions of the Municipal Code of Chicago.

The grantee shall pay to the City of Chicago as compensation for the privilege #1141825 herein granted the sum of one hundred (\$100.00) per annum in advance.

A 25% penalty will be added for payments received after due date.

The permit holder agrees to hold the City of Chicago harmless for any damage, relocation or replacement costs associated with damage, relocation or removal of private property caused by the City performing work in the public way.

Authority herein given and granted for a period of five (5) years from and after 04/22/2019.

Alderman _____

Daniel LaSpata 1st Ward

Pot Pan Thai
1362 N. Milwaukee Av.
Chicago Il. 60622

Side View

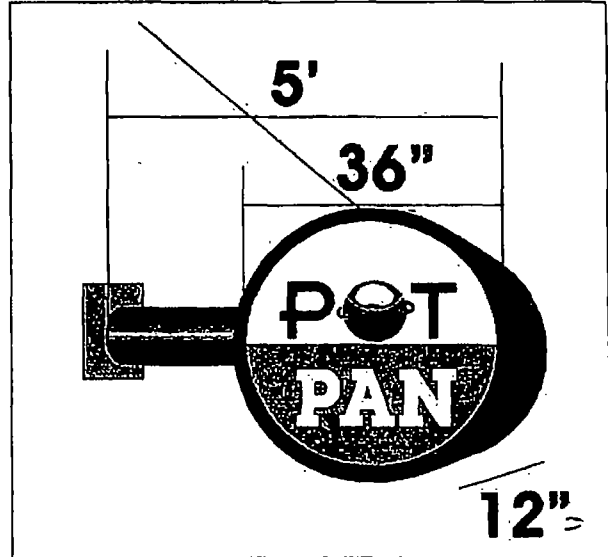
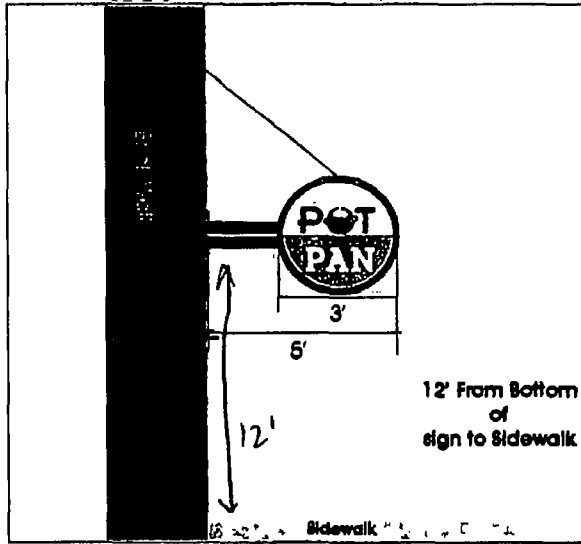

Top View

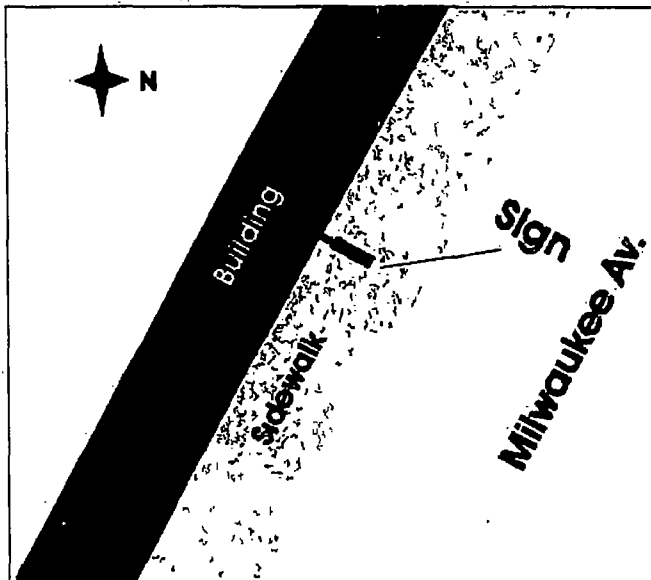

- 1 Standard double face projecting sign
- 2 lexan faces.
- Illuminated with flourescent lamps
- Angle Iron swing support
- Chain top support

 **PYRAMID**
DESIGN INC
2218 W GRAND AV
CHICAGO IL 60612
(847) 381-8033
PYRAMIDDESIGNMEN.COM



09/09/2020

Alderman Daniel LaSpata
Ward # 01
City of Chicago
City Hall, Room 300
121 North LaSalle Street
Chicago, Illinois 60602

Re: An ordinance to use and maintain a portion of the public right-of-way for **one (1) sign(s)** for **POT PAN RESTAURANT**, adjacent to the premises known as **1362 N. Milwaukee Ave.**.

Dear Alderman **Daniel LaSpata**:

The applicant referenced above has requested the use of the public right-of-way for a **sign(s)**. An ordinance has been prepared by the Department of Business Affairs and Consumer Protection – Small Business Center - Public Way Use Unit for presentation to the City Council. Because this request was made for properties located in your ward, as approved by you as per the attached, I respectfully request that you introduce the attached ordinance at the next City Council meeting.

If you have any questions regarding this ordinance, please contact Anthony Bertuca at (312) 744-5506.

Department of Business Affairs and Consumer Protection