



City of Chicago



O2021-1015

Office of the City Clerk

Document Tracking Sheet

Meeting Date: 3/24/2021
Sponsor(s): Martin (47)
Type: Ordinance
Title: Grant(s) of privilege in public way for Merz Apothecary/Q
Brothers
Committee(s) Assignment: Committee on Transportation and Public Way

ORDINANCE
MERZ APOTHECARY/ Q BROTHERS
Acct. No. 26979 - 2
Permit No. 1147952

Be It Ordained by the City Council of the City of Chicago:

SECTION 1. Permission and authority are hereby given and granted to MERZ APOTHECARY/ Q BROTHERS, upon the terms and subject to the conditions of this ordinance to maintain and use one (1) sign(s) projecting over the public right-of-way attached to its premises known as 4718 N. Lincoln Ave..

Said sign structure(s) measures as follows; along N. Lincoln Avenue:
One (1) at six point zero eight (6.08) feet in length, three (3) feet in height and eleven point two five (11.25) feet above grade level.

The location of said privilege shall be as shown on prints kept on file with the Department of Business Affairs and Consumer Protection and the Office of the City Clerk.

Said privilege shall be constructed in accordance with plans and specifications approved by the Department of Transportation (Division of Project Development) and Zoning Department - Signs.

This grant of privilege in the public way shall be subject to the provisions of Section 10-28-015 and all other required provisions of the Municipal Code of Chicago.

The grantee shall pay to the City of Chicago as compensation for the privilege #1147952 herein granted the sum of one hundred (\$100.00) per annum in advance.

A 25% penalty will be added for payments received after due date.

The permit holder agrees to hold the City of Chicago harmless for any damage, relocation or replacement costs associated with damage, relocation or removal of private property caused by the City performing work in the public way.

Authority herein given and granted for a period of five (5) years from and after 02/10/2021.

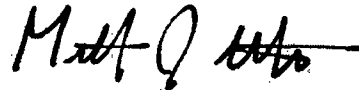

Alderman _____

Matt Martin 47th Ward

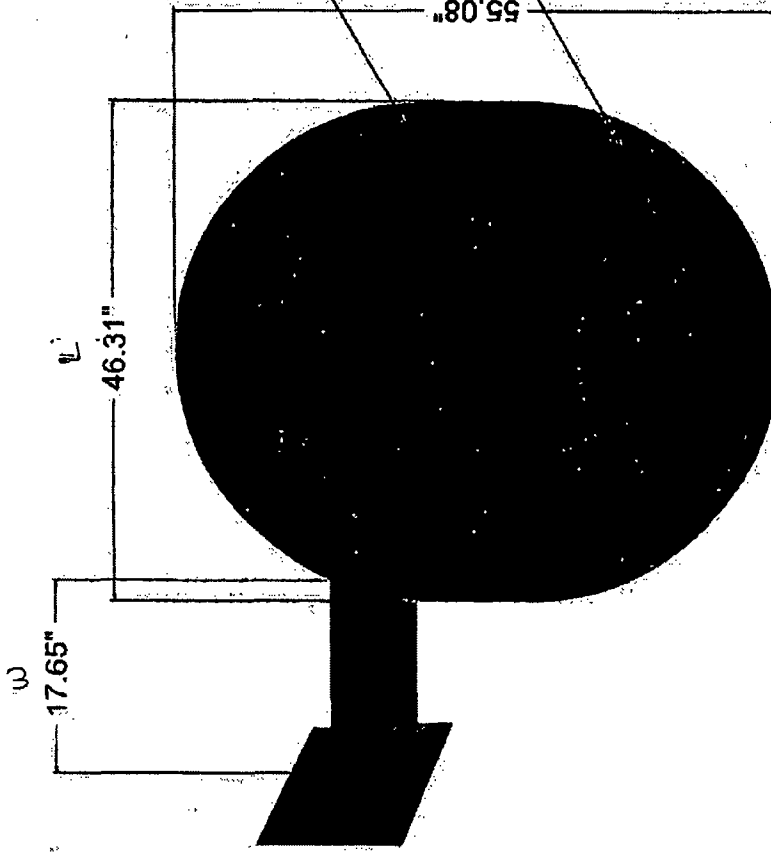

Non-illuminated Aluminum painted to be black paint is: 41306SP Signal Jet Black LRV 4.2

Gold Acrylic to be decorated w/ 091 Gold Translucent Vinyl

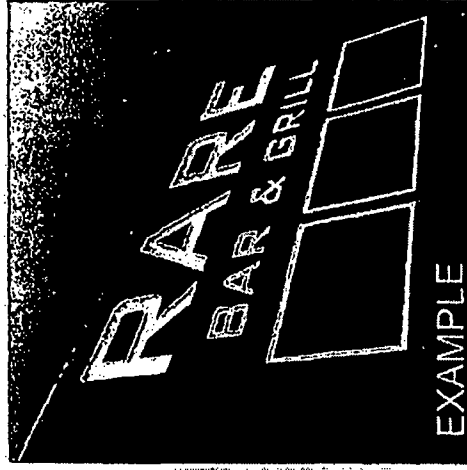

Aluminum Cut Out

SPECIFICATIONS FOR FABRICATION

- Extruded aluminum construction type: Large
- Cabinet Depth: 8"
- Retainer size: 2"
- Primary electrical requirement: 120 volt (installed within six feet of sign by others)
- Illumination: LEDS
Timer or photo-cell (installed by others)

| | | | | |
|--|---|---|---|--|
| <p>5500 N. Kedzie Ave Chicago, IL 60625 773-267-6007 sales@tfsigns.com</p> | <p>Client Name: Merz Apothecary</p> <p>Location: 4718 N. Lincoln Ave, Chicago, IL</p> | <p>Start Date: Last Revision: Job#: Drawing#: Page: 1 of 2</p> | <p>Client Approval</p> <p>Landlord Approval</p> | <p>Sales Rep: Seung</p> <p>Designer: Seung</p> |
| | <p>.....</p> | | | |



Department of Business Affairs and Consumer Protection
Small Business Center - Public Way Use Unit
City Hall - 121 N. LaSalle Street, Room 800 • Chicago, IL 60602
312-74-GOBIZ / 312-744-6249 • (312) 744-1944 (TTY)
<http://www.cityofchicago.org/bacp>

03/24/2021

Alderman Matt Martin
Ward # 47
City of Chicago
City Hall, Room 200
121 North LaSalle Street
Chicago, Illinois 60602

Re: An ordinance to use and maintain a portion of the public right-of-way for one (1) sign(s) for MERZ APOTHECARY/ Q BROTHERS, adjacent to the premises known as 4718 N. Lincoln Ave..

Dear Alderman Matt Martin:

The applicant referenced above has requested the use of the public right-of-way for a sign(s). An ordinance has been prepared by the Department of Business Affairs and Consumer Protection – Small Business Center - Public Way Use Unit for presentation to the City Council. Because this request was made for properties located in your ward, as approved by you as per the attached, I respectfully request that you introduce the attached ordinance at the next City Council meeting.

If you have any questions regarding this ordinance, please contact Anthony Bertuca at (312) 744-5506.

Department of Business Affairs and Consumer Protection