



# City of Chicago



O2021-2046

Office of the City Clerk

## Document Tracking Sheet

<b>Meeting Date:</b>	5/26/2021
<b>Sponsor(s):</b>	Reilly (42)
<b>Type:</b>	Ordinance
<b>Title:</b>	Grant(s) of privilege in public way for Fordham Condo, The
<b>Committee(s) Assignment:</b>	Committee on Transportation and Public Way

ORDINANCE

THE FORDHAM CONDOMINIUM

Acct. No.: 300373 - 1

Permit No: BACP1531467

*Be It Ordained by the City Council of the City of Chicago:*

SECTION 1. Permission and authority are hereby given and granted to THE FORDHAM CONDOMINIUM upon the terms and subject to the conditions of this ordinance to maintain and use, as now constructed, eight (8) Light Fixture(s) projecting over the public right-of-way adjacent to its premises known as 25 E SUPERIOR ST.

Said Light Fixture(s) at E. SUPERIOR measure(s):

Two (2) at one point five (1.5) feet in length, Zero (0) feet in width and seven point five eight (7.58) feet above grade level.

Two (2) at one (1) feet in length, Zero (0) feet in width and seven point five eight (7.58) feet above grade level.

Said Light Fixture(s) at N. WABASH measure(s):

Two (2) at one (1) feet in length, Zero (0) feet in width and seven point five eight (7.58) feet above grade level.

Said Light Fixture(s) at E. HURON measure(s):

Two (2) at one (1) feet in length, Zero (0) feet in width and seven point five eight (7.58) feet above grade level.

The location of said privilege shall be as shown on prints kept on file with the Department of Business Affairs and Consumer Protection and the Office of the City Clerk.

Said privilege shall be constructed in accordance with plans and specifications approved by the Department of Transportation (Division of Project Development).

This grant of privilege in the public way shall be subject to the provisions of Section 10-28-015 and all other required provisions of the Municipal Code of Chicago.

The grantee shall pay to the City of Chicago as compensation for the privilege #BACP1531467 herein granted the sum of one hundred ten (\$110.00) per annum in advance.

A 25% penalty will be added for payments received after due date.

The permit holder agrees to hold the City of Chicago harmless for any damage, relocation or replacement costs associated with damage, relocation or removal of private property caused by the City performing work in the public way.

Authority herein given and granted for a period of five (5) years from and after 05/02/2021.

Alderman:

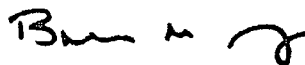

---

Brendan Reilly 42nd Ward

CORNER GUARD DETAIL

9 TYPICAL CABLE GUARD ELEVATION

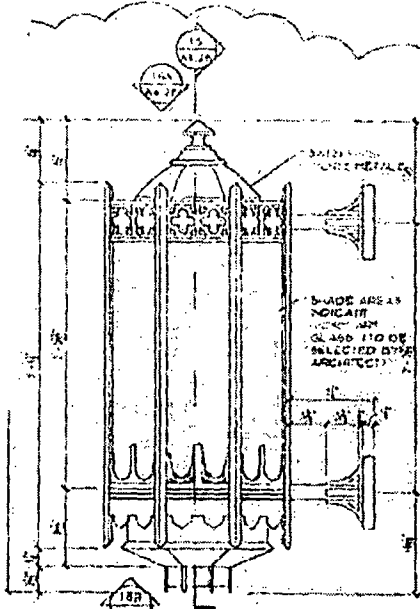

4 EXT. SCONCE ELEV. (EX-1)  
SCALE: 1/2" = 1'-0"

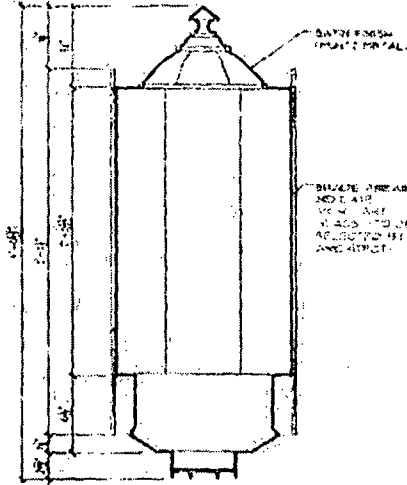

15 EXT. SCONCE SECT. (EX-1)  
SCALE: 1/2" = 1'-0"

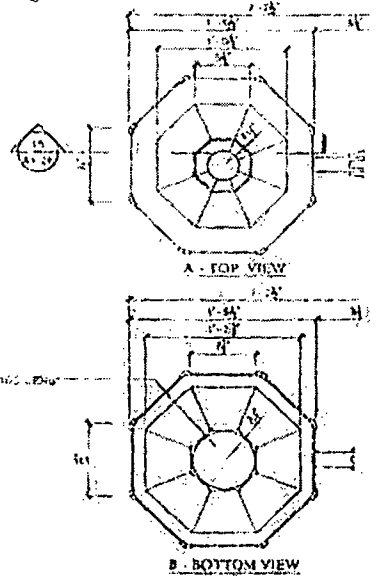

16 EXT. SCONCE PLANS (EX-1)  
SCALE: 1/2" = 1'-0"

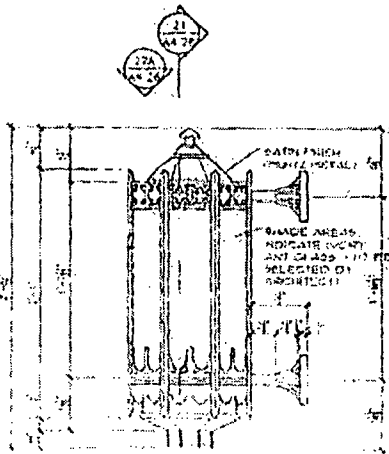

20 EXT. SCONCE ELEV. (EX-2)  
SCALE: 1/2" = 1'-0"

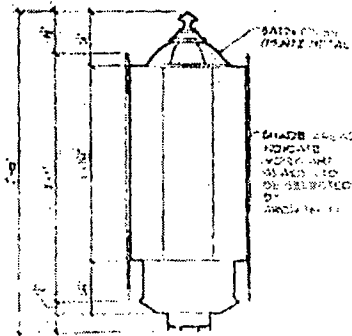

21 EXT. SCONCE SECT. (EX-2)  
SCALE: 1/2" = 1'-0"

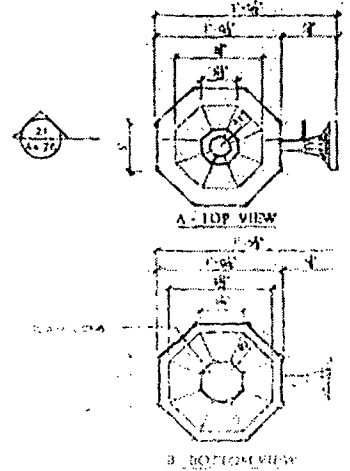

22 EXT. SCONCE PLANS (EX-2)  
SCALE: 1/2" = 1'-0"



**Department of Business Affairs and Consumer Protection**  
Small Business Center - Public Way Use Unit  
City Hall - 121 N. LaSalle Street, Room 800, Chicago, IL 60602  
312-74-GOBIZ / 312-744-6249 • (312) 744-1944 (TTY)  
<http://www.cityofchicago.org/bacp>

05/26/2021

Alderman Brendan Reilly  
Ward # 42  
City of Chicago  
City Hall, Room 800  
121 N. LaSalle Street  
Chicago, IL 60602

Re: An ordinance to use and maintain a portion of the public right-of-way for **8 Light Fixture(s)** for **THE FORDHAM CONDOMINIUM**, adjacent to the premises known as **25 E SUPERIOR ST.**

Dear Alderman **Brendan Reilly**:

The applicant referenced above has requested the use of the public right-of-way for **Light Fixture(s)**. An ordinance has been prepared by the Department of Business Affairs and Consumer Protection - Small Business Center - Public Way Use Unit for presentation to the City Council. Because this request was made for properties located in your ward, as approved by you as per the attached, I respectfully request that you introduce the attached ordinance at the next City Council meeting.

If you have any questions regarding this ordinance, please contact Anthony Bertuca at (312) 744-5506.

**Department of Business Affairs and Consumer Protection**