



City of Chicago



Or2021-277

Office of the City Clerk

Document Tracking Sheet

Meeting Date:	10/14/2021
Sponsor(s):	Dowell (3)
Type:	Order
Title:	Issuance of permits for sign(s)/signboard(s) at 2300 S State St - southeast corner
Committee(s) Assignment:	Committee on Zoning, Landmarks and Building Standards

CITY COUNCIL
COMMITTEE ON ZONING, LANDMARKS AND BUILDING STANDARDS

COUNCIL ORDER

RE: Approval of sign over 100 square feet in area or over 24 feet above grade

ORDERED, that the City Council hereby approves the following sign application submitted by:

Applicant*: Southbridge

(* The Applicant is the owner of the real property or the business tenant of the real property. Do not list the sign contractor, sign erector, sign company or advertising entity in the above space.)

This Order approves the following sign in accordance with Municipal Code of Chicago Section 13-20-680:

Address of Sign: 2300 S State Street Chicago, IL 60616

Zoning District: PD1419

DOB Sign Permit Application #: TBD

Sign Details:

1. On-premise OR Off-premise
2. Static sign OR Dynamic-image display sign
3. Number of sign faces 1
4. Projecting over the public way No (Yes or No) If yes, Public Way Use #: _____
5. Dimensions: Length 16 feet 0 inches Height 8 feet 0 inches
Total square feet in area: 128 feet _____ inches
6. Height above grade: 15' feet _____ inches
7. Elevation (side of building or lot where the sign will be erected): southeast corner
8. Name of Sign Contractor/Erector: Parvin-Clauss Sign Co

To be legal, such sign shall comply with all provisions of Title 17 of the Chicago Municipal Code ("Zoning Ordinance") and all other provisions of the Municipal Code governing the permitting, construction and maintenance and removal of signs and sign structures. Failure of the applicant and the applicant's successors to comply shall be grounds for invalidation or revocation of the sign permit.



Alderman

3rd

Ward

16'-0"

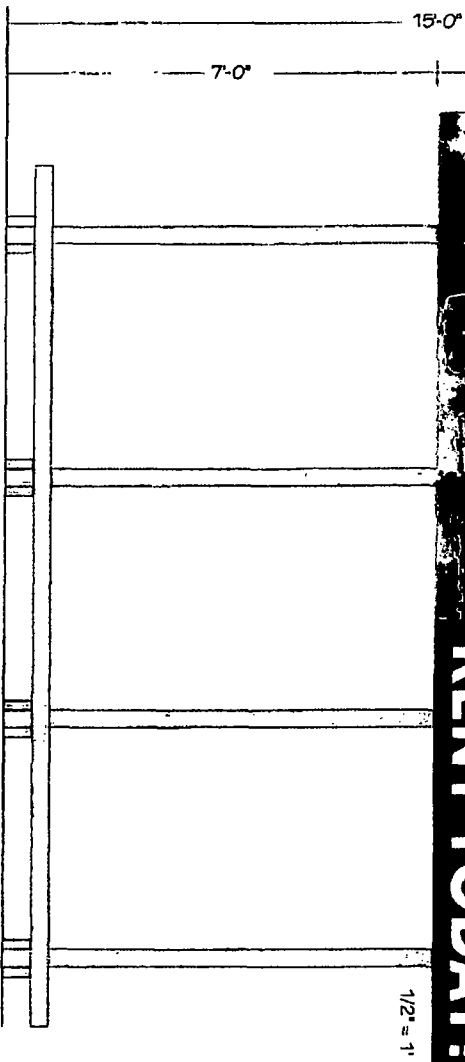

- (2) 8'-0" x 16'-0" single face mdo plywood signs on wood platform
- Substrate: 3/8" thick mdo plywood w/digitally printed vinyl graphics applied
- *23rdPlaceChicago.com... Two-Bedrooms" & "RENT TODAY": White on CMYK Maroon (37,99,71,56)
- *23rd Place Logo: White on full-color rendering supplied by customer.
- Wood Platform: 2" x 4's, 2" x 6's and 4" x 4's painted Bridgewater Grey.
- Includes bagged concrete weights



This sign is built to UL Standards for operation in North America.

This Document is owned by, and the information contained in it is proprietary to Parvin-Claus Sign Company. By receipt hereof the holder agrees not to use the information, disclose it to any third party, nor reproduce this document without the prior written consent of Parvin-Claus Sign Company. Holder also agrees to immediately return this document upon request of Parvin-Claus Sign Company.

Copyright 2011 by Parvin-Claus Sign Co.

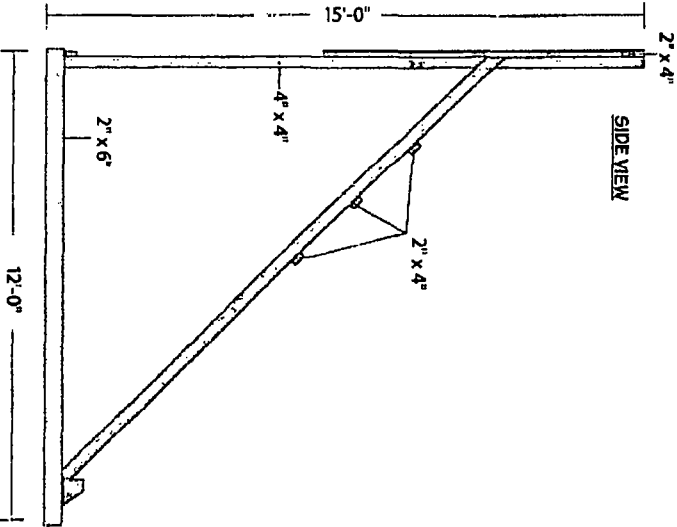
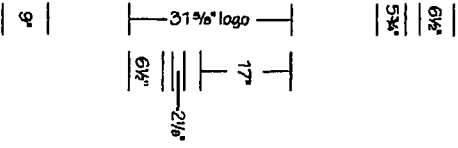

Parvin-Claus
SIGN COMPANY

Design • Fabrication • Installation • Maintenance

16578e-wy/Dive-Croftswam-illinois60148
Tel/30.510.2020 • Fax/630.510.1074
e-mail/1:234@parvinclaus.com
www.parvinclaus.com

PROJECT:

SOUTHRIDGE

2300 S. State St.,
CHICAGO, IL 60616

CUSTOMER APPROVAL:

DATE

AUTHORIZED SIGNATURE

REPRESENTATIVE

Brian Newton / KZ

DRAWN BY

JP

DATE

8.5.21

SCALE

as noted

SHEET NO.

1 of 2

ESTIMATE / JOB NUMBER

7612 /

FILE NAME

SB7612

PRINT INFO

REVISIONS:

- 8.16.21 - new art
- 8.19.21 - letter heights
- 8.26.21 - layout
- 9.7.21 - scope of work
- 9.14.21
-
-

SOUTHBRIDGE

BANNER

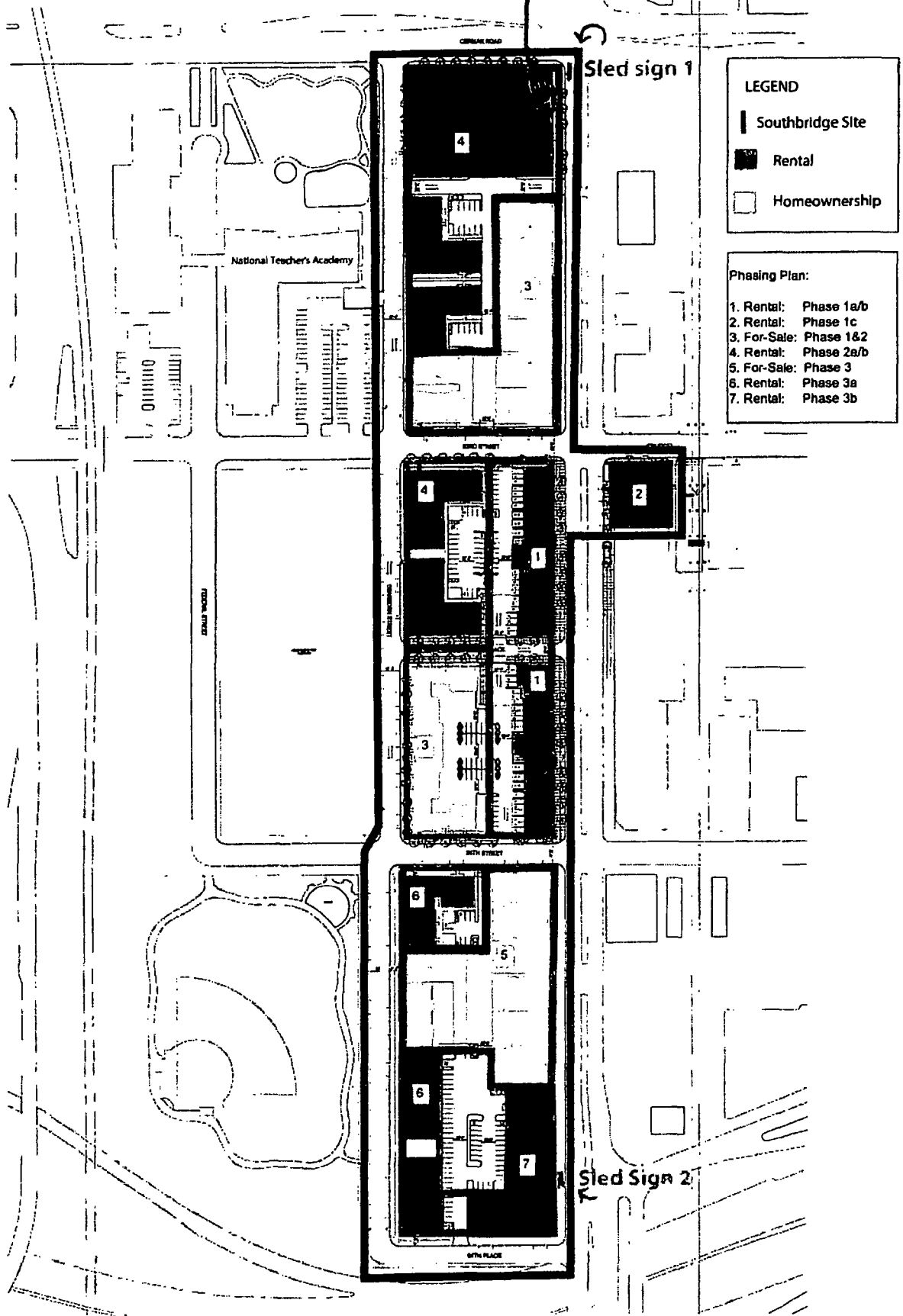

LEGEND

- ▬ Southbridge Site
- Rental
- Homeownership

Phasing Plan:

- 1. Rental: Phase 1a/b
- 2. Rental: Phase 1c
- 3. For-Sale: Phase 1&2
- 4. Rental: Phase 2a/b
- 5. For-Sale: Phase 3
- 6. Rental: Phase 3a
- 7. Rental: Phase 3b

